

FUJINON CCTV LENSES

for Security & Surveillance

Vari-Focal HD Vari-Focal (3M)

Vari-Focal HD Vari-Focal (1.3M)

Fixed Focal HD Fixed Focal (5M)

Fish-Eye

Vari-Focal

Zoom

Fixed Focal





FUJINON

Optical Device Business Division of FUJIFILM Corporation (former FUJINON Corporation) made a fresh start. As a product brand, FUJINON re-emerged with the creation of a new logo. The FUJINON brand will continue growing and progress further based on our concrete technical heritage.

See what it is, not what it might be. FUJINON CCTV LENSES

Vari-Focal HD Vari-Focal (3M)

Vari-Focal HD Vari-Focal (1.3M)

Fixed Focal HD Fixed Focal (5M)

Fish-Eye

Vari-Focal

Zoom

Fixed Focal

Zoom Lens Wiring

Technical Information

FUJINON CCTV LENSES *For Security & Surveillance*

Features



Fish-Eye Lenses

Fujinon's Fish-Eye lens, with an angle of 185 degrees, is the world's first to support 5 megapixel CCD cameras. High-quality image display in imaging software has been made simple with captured images that are sharp from edge to edge, and with the adoption of the $F\theta$ system suited for uniform displaying of images. Look no further for effective, blindspot-free wide-area surveillance, such as of subway entrances and shopping arcades.



Fixed Focal Length Lenses

High cost-performance fixed focal length lenses that are compact, lightweight and of course provide high quality images for security CCTV cameras. Great lineups including day-and-night use lenses supporting 5-megapixel cameras, which are optimum for ITS in growing demand. These lenses are highly effective wherever security monitoring is required, including bank ATMs, convenience stores, offices, condominiums and transportation facilities.



HD Vari-Focal Lenses

High-resolution lenses for use in security systems for which demand has grown in recent years. These lenses boast super clear imaging from the center to the edges with superior face recognition capability. The lenses are suitable for any purpose and locale, in day and night use, from among focal lengths of 2.2 mm to 80 mm.



Vari-Focal Lenses

Lenses for use in security systems for which demand has grown in recent years. These lenses allow clear imaging from the center to the edges with superior face recognition capability. They are suitable for any purpose and locale.

The lenses are featured by: an AT aspheric surface, large aperture of F0.95, day and night use, miniature design for dome application or coverage for 1/2-inch sensors superior in terms of optical performance.



Zoom Lenses

With the adoption of high-precision TRI-CAM + INNERCAM technology, we offer an expanded lineup of products to meet ever more diversified needs. There are models with auto-focusing, optical anti-vibration, zoom and focus presetting, and also those which support the RS-232C standard that enable sophisticated zoom control by computer. We are expanding the lineup with lenses for night vision cameras and lenses with super zoom (eg: 60x), long focal length (eg: 2200 mm) or high resolution (eg: 2 megapixels) demanded for long range surveillance. Small and lightweight lenses enable compact long range surveillance systems to be built.



Day & Night Lenses

There is a growing need for compact, high quality lenses for 24/7 surveillance applications such as parking lots, factory premises, streets.

Continuous surveillance is also required for public facilities such as airports, harbors, highways and border patrol, requiring more versatile focal lengths and higher zoom ratios.

Fujinon has developed lenses that respond to infrared illumination to capture clear, corrected images, even at 0 lux. We offer a lineup of lenses from the standard focal length of 2.9-8 mm, to the diverse focal length of 12.5-2200 mm.

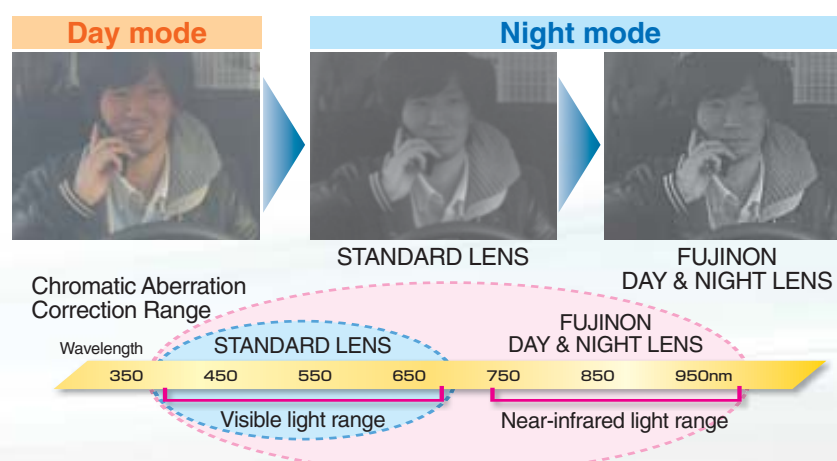

At night, day & night cameras operate in the near-infrared range. For this reason, use of regular lenses causes the image to be out of focus. Using special optical glass and advanced optical designing technology, Fujinon's day&night lenses achieve minimal axial aberration. Sharp and high quality images can be captured around-the-clock, whether in the visible range (day / color) or in the near-infrared range (night / monochrome), and at every focal distance from the wide end to the tele end.

Focal Length

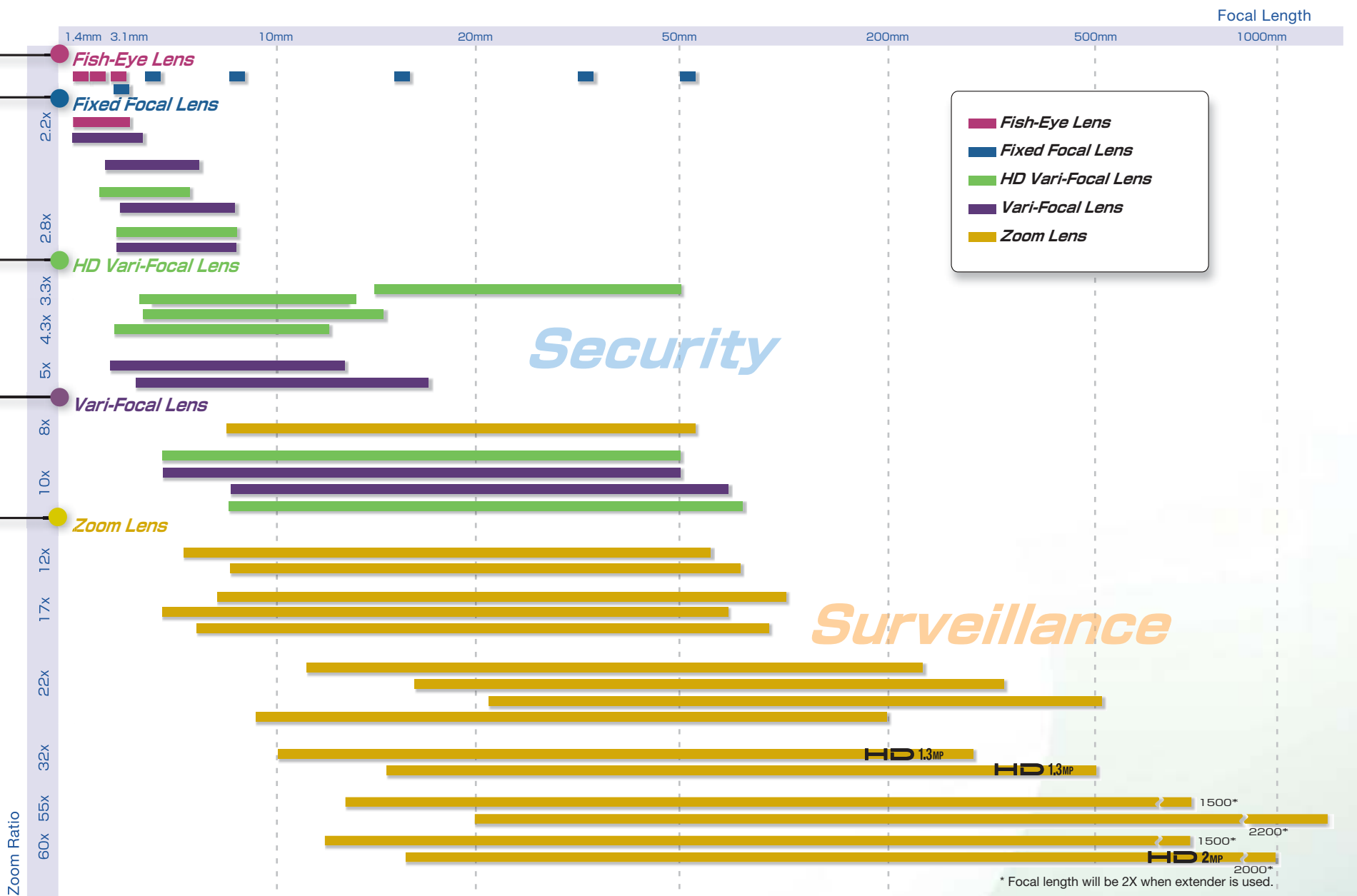

Feature Indications

Lens Type Fixed Focal High performance single focal lens for the best image quality	Vari-Focal Variable magnification lens with manually controllable angle. It functions as if you have multiple fixed focal lenses	Zoom Zoom lens with the high performance cam adopted, which offers high quality smooth movements			
Feature/Function 5 Mpx HD High performance to fully exploit 5 megapixel HD cameras' high resolution	3 Mpx HD High performance to fully exploit 3 megapixel HD cameras' high resolution	2 Mpx HD High performance to fully exploit 2 megapixel HD cameras' high resolution	1.3 Mpx HD High performance to fully exploit 1.3 megapixel HD cameras' high resolution		
Day & Night Specially-designed lens supporting both visible light and near-infrared light to prevent out-of-focus of day & night cameras	Visible Light Cut Filter Blocks visible light, allowing the capturing of image using only near-infrared light	Fish-Eye Super wide angle lens realizing angle of 185 degrees	Motor Drive Enables the lens control from remote locations	Telephoto Long Focal Telephoto lens with the ability to zoom	Wide Angle Wide angle lens which ensures wide field of view
Auto Focus Easy and sharp auto-focusing even in zooming	Optical Anti-Vibration High-intensity optical vibration isolation system, optimizing the image in any circumstances	For 3CCD Camera Lens exclusively for 3CCD cameras for the optimum color reproduction and high resolution of 3CCD cameras	Built-in Cast-in lens resulted from abolition of the standard mounting method, enabling the downsizing of your system	Potential Meter Enables to preset the zoom, focus and iris positions of the zoom lens	ND Filter With the built-in ND filter, enables to optimize the brightness of the bright object in direct sunlight
Extender Function to double the focal length by one-touch control	PC Control Enables the advanced control of zoom lens using a PC	Long Cable Cable length options provided to let you select the best-suited length for your camera	Full Servo DC servo circuit enabling the smooth movement and accurate positioning	Aspherical Lens Adopts the aspheric lens technologies developed in the most advanced lenses for broadcasting	RoHS Compliant
Iris Type Manual Iris Manually-operated iris	Remote Iris Motor-driven iris	DC Auto Iris Auto iris supporting DC-controlled cameras	Video Auto Iris Auto iris supporting video-controlled cameras	Iris-Remote Allows switching between auto iris and remote iris	
Mounting Type C Mount Screw-in mounting commonly used in FA lenses	CS Mount Screw-in mounting commonly used in security lenses	Metal Mount Metal mounting with high accuracy and durability			
Large Aperture Ratio Bright lenses with large aperture ratio, fully exploiting camera sensitivity 					

Vari-Focal
HD Vari-Focal (3M)

Vari-Focal
HD Vari-Focal (1.3M)

Fixed Focal
HD Fixed Focal (5M)

Fish-Eye

Vari-Focal

Zoom

Fixed Focal

Zoom Lens Wiring

Technical Information

HD Lenses

As modern industries and social infrastructures are growing rapidly, demands for surveillance systems incorporating high-definition cameras are increasing day by day. In order to fully utilize advanced complex security systems, superior lens performance for image capture is essential.

To respond to this market demand, Fujifilm offers a wide variety of high quality lenses for HD security cameras, achieving clear images for superior face recognition capability.

Suitable for any application and condition, our lineup contains Day and Night, and other lenses ranging from 2.2 mm to 2200 mm.

HD
5MP

HD
3MP

HD
2MP

HD
1.3MP



HD

High-vision surveillance images!

Lenses supporting 1.3- to 5-megapixel HD sensors provide 2 to 4 times greater resolution, compared to traditional lenses for SD sensors. Only when used in combination with these lenses, cameras with greater pixel sizes and image quality allowed to fully exercise their performance.

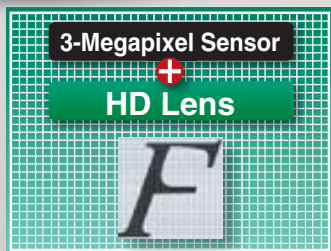

Image captured by HD lens for 3-megapixel sensor

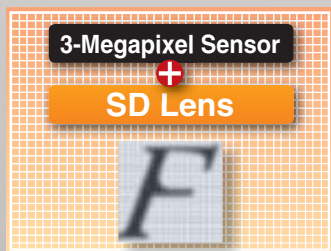
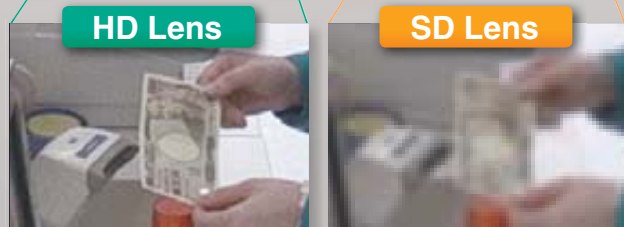

Image captured by SD lens

* The above are simulated images of those captured by HD lens/SD lens and 3-megapixel sensor.

● **Over Cash Register**



Details on banknotes or cash display are clearly seen.

● **In Store**

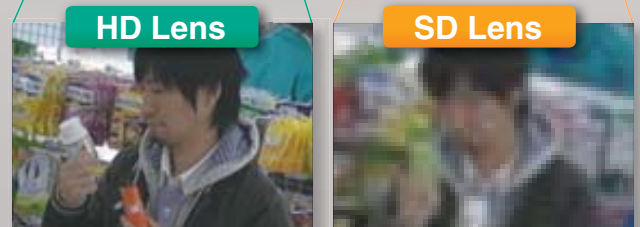

Facial expressions or details of clothing can be easily seen in images taken by HD lenses.

YV2.8x2.8SR4A-SA2

2.8x Applicable camera (model) 1 2/3 1/2 1/2.7 1/3 1/4

NEW



HD
3MP
Day Night

Applicable to
1/2.7

Coming Soon

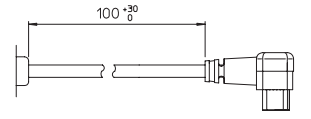
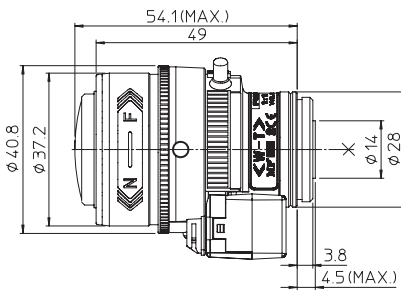
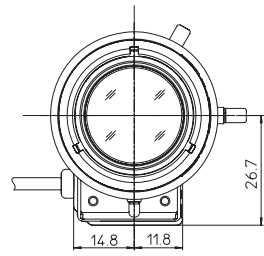

Unit : mm

Vari-Focal Wide Angle DC Auto Iris CS Mount Metal Mount ND Filter Long Cable Aspherical Lens Large Aperture Ratio RoHS Compliant

VARI **WIDE** **DC** **CS-mt** **METAL** **ND** **230** **AT** **F1.3** **RoHS**

YV2.7x2.2SR4A-SA2

2.7x Applicable camera (model) 1 2/3 1/2 1/2.7 1/3 1/4

NEW



HD
3MP
Day Night

Applicable to
1/2.7

Coming Soon

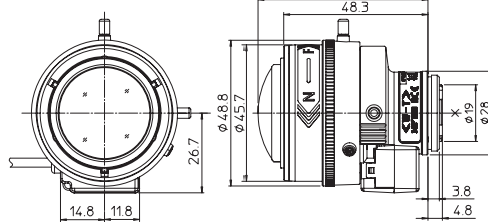

Unit : mm

Vari-Focal Wide Angle DC Auto Iris CS Mount Metal Mount ND Filter Long Cable Aspherical Lens Large Aperture Ratio RoHS Compliant

VARI **WIDE** **DC** **CS-mt** **METAL** **ND** **230** **AT** **F1.3** **RoHS**

YV2.1x2.8SR4A-SA2

2.1x Applicable camera (model) 1 2/3 1/2 1/3 1/4

NEW



HD
3MP
Day Night

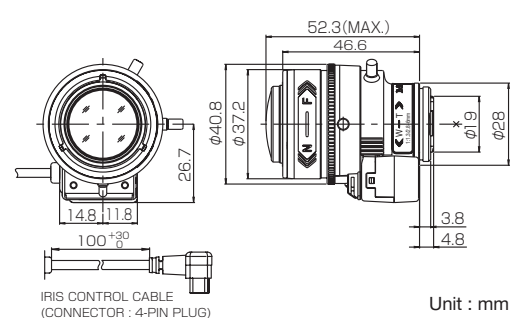

Unit : mm

Vari-Focal Wide Angle DC Auto Iris CS Mount Metal Mount ND Filter Long Cable Aspherical Lens Large Aperture Ratio RoHS Compliant

VARI **WIDE** **DC** **CS-mt** **METAL** **ND** **230** **AT** **F1.3** **RoHS**

DV10x8SR4A-SA1

10x Applicable camera (model) 1 2/3 1/2 1/3 1/4

NEW



HD
3MP
Day Night

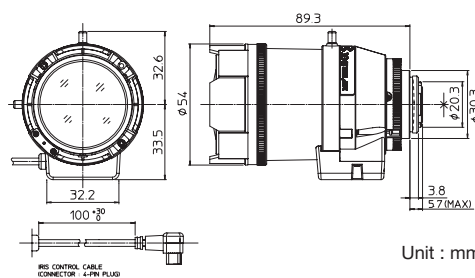

Unit : mm

Vari-Focal Telephoto Long Focal DC Auto Iris C Mount Metal Mount ND Filter Long Cable Aspherical Lens Large Aperture Ratio RoHS Compliant

VARI **TELE** **DC** **C-mt** **METAL** **ND** **230** **AT** **F1.6** **RoHS**

* Photograph is a similar model.

DV3.8x4SR4A-SA1

3.8x Applicable camera (model) 1 2/3 1/1.8 1/2 1/3 1/4

NEW



HD
3MP
Day Night



Unit : mm

Vari-Focal Wide Angle DC Auto Iris C Mount Metal Mount ND Filter Long Cable Aspherical Lens Large Aperture Ratio RoHS Compliant

VARI **WIDE** **DC** **C-mt** **METAL** **ND** **230** **AT** **F1.5** **RoHS**

	NEW	NEW	Applicable to 1/2	NEW	Applicable to 1/1.8	NEW
	YV2.8x2.8SR4A-SA2	YV2.7x2.2SR4A-SA2	YV2.1x2.8SR4A-SA2	DV10x8SR4A-SA1	DV3.8x4SR4A-SA1	
Focal Length (mm)	2.8 - 8 (2.8x)	2.2 - 6 (2.7x)	2.8 - 6 (2.1x)	8 - 80 (10x)	4 - 15.2 (3.8x)	
Iris Range	F1.3 - T360		F1.3 - T360 (Equivalent to F360)	F1.6 - T360	F1.5 - T360	
Operation	Zoom	Manual		Manual		
	Focus	Manual		Manual		
	Iris	Auto (DC type)*1		Auto (DC type)*1		
Angle of View (H x V)	1/1.8"	WIDE	—	—	103° 27' x 77° 03'	
		TELE	—	—	27° 23' x 20° 34'	
	1/2"	WIDE	—	—	44° 26' x 33° 41'	92° 42' x 69° 08'
		TELE	—	—	4° 44' x 3° 34'	24° 38' x 18° 29'
	1/2.7"	WIDE	112° 33' x 81° 21'	132° 51' x 100° 22'	—	—
		TELE	38° 53' x 29° 8'	50° 26' x 37° 56'	—	—
1/3"	WIDE	100° 34' x 73° 22'	121° 4' x 91° 20'	101° 11' x 74° 10'	—	
	TELE	35° 16' x 26° 26'	45° 51' x 34° 28'	46° 58' x 35° 09'	—	
Angle of View (H x V) Aspect Ratio 16:9	1/1.8"	WIDE	—	—	113° 02' x 62° 46'	
		TELE	—	—	29° 48' x 16° 49'	
	1/2"	WIDE	—	—	48° 9' x 27° 38'	101° 14' x 56° 21'
		TELE	—	—	5° 9' x 2° 55'	26° 49' x 15° 07'
	1/2.7"	WIDE	125° 6' x 65° 35'	144° 17' x 82° 13'	—	—
		TELE	42° 23' x 23° 47'	54° 53' x 31° 1'	—	—
1/3"	WIDE	111° 8' x 59° 19'	131° 34' x 74° 46'	111° 25' x 60° 03'	—	
	TELE	38° 27' x 21° 35'	49° 55' x 28° 11'	51° 13' x 28° 41'	—	
Focus Range (From the Lens Front) (m)	∞ - 0.3		∞ - 0.3	∞ - 1.5	∞ - 0.3	
Mass (g)	60	75	55	180	110	

* 1: The iris automatically closes when the camera is turned off.

* Each of the above products is also available in a manual type. * Each of the above products is also available in a long cable type (230 mm).

For detailed specifications, see the following website: http://www.fujifilm.com/products/optical_devices/cctv/security/

Vari-Focal HD

HD Vari-Focal (3M) **3MP**

YV2.8x2.8SA-SA2 **2.8x** Applicable camera (model) 1 2/3 1/2 1/3 1/4

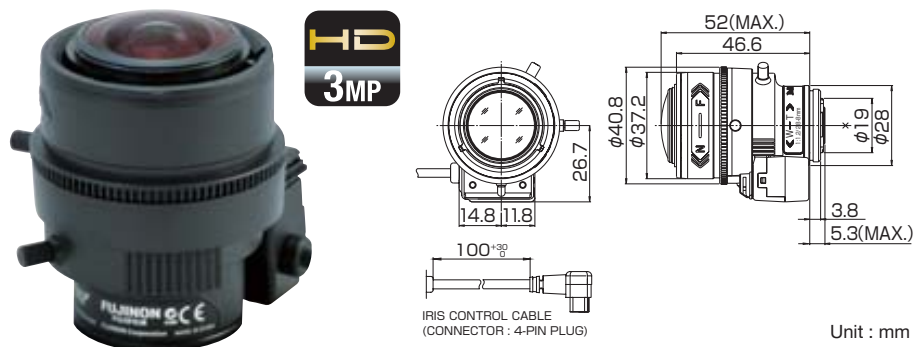

Unit : mm



YV2.7x2.2SA-SA2 **2.7x** Applicable camera (model) 1 2/3 1/2 1/3 1/4

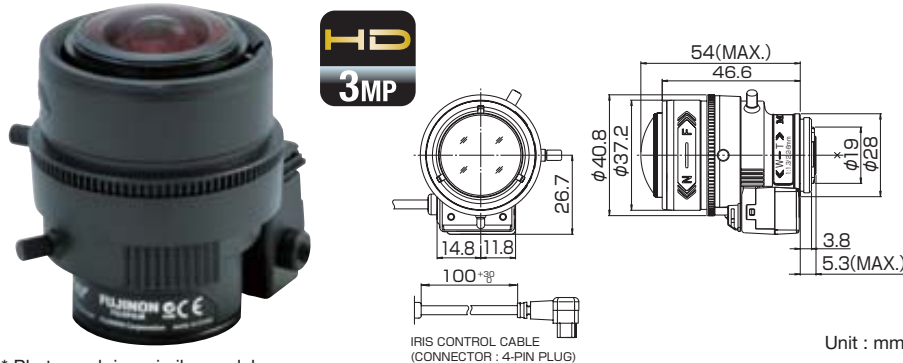

Unit : mm

* Photograph is a similar model.



YV4.3x2.8SA-SA2 **4.3x** Applicable camera (model) 1 2/3 1/2 1/3 1/4

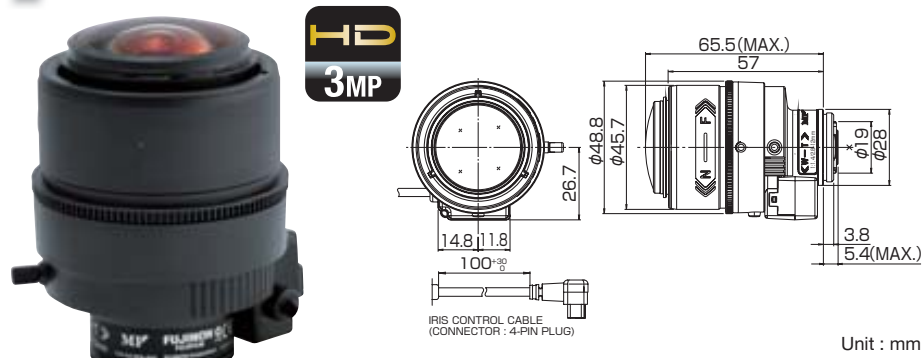

Unit : mm



YV3.3x15SA-SA2 **3.3x** Applicable camera (model) 1 2/3 1/2 1/3 1/4

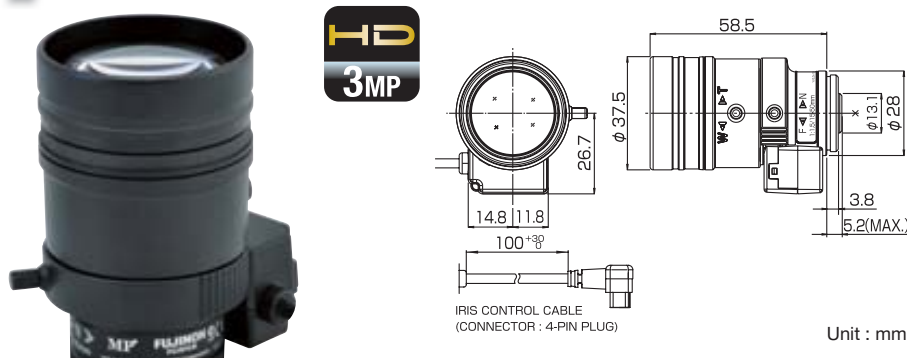

Unit : mm



DV3.4x3.8SA-SA1 **3.4x** Applicable camera (model) 1 2/3 1/2 1/3 1/4

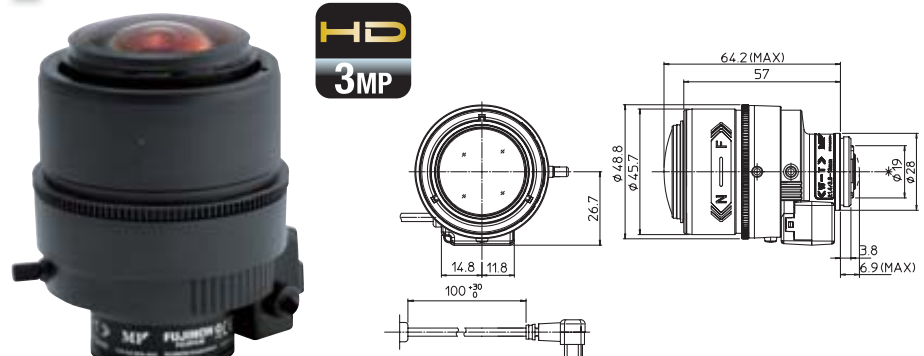

Unit : mm

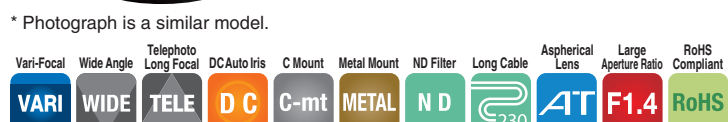

DV10x8SA-SA1 **10x** Applicable camera (model) 1 2/3 1/2 1/3 1/4

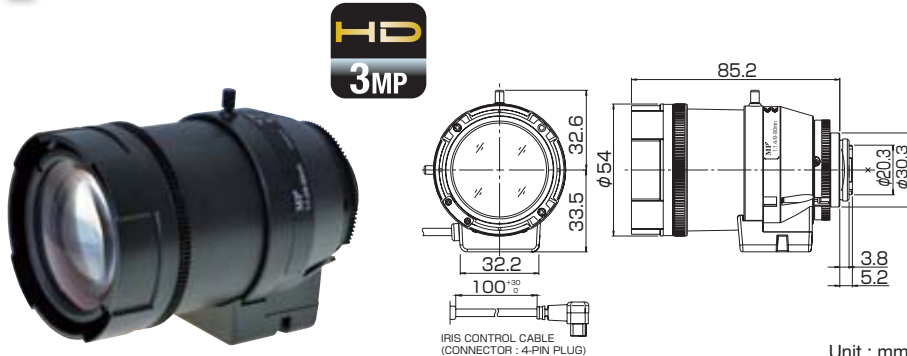

Unit : mm



* Photograph is a similar model.

		YV2.8x2.8SA-SA2	YV2.7x2.2SA-SA2	YV4.3x2.8SA-SA2	YV3.3x15SA-SA2	DV3.4x3.8SA-SA1 <small>Applicable to 1/2</small>	DV10x8SA-SA1 <small>Applicable to 1/2</small>	
Focal Length (mm)		2.8 - 8 (2.8x)	2.2 - 6 (2.7x)	2.8 - 12 (4.3x)	15 - 50 (3.3x)	3.8 - 13 (3.4x)	8 - 80 (10x)	
Iris Range		F1.2 - T360 (Equivalent to F360)	F1.3 - T360 (Equivalent to F360)	F1.4 - T360 (Equivalent to F360)	F1.5 - T360 (Equivalent to F360)	F1.4 - T360 (Equivalent to F360)		
Operation	Zoom	Manual					Manual	
	Focus	Manual					Manual	
	Iris	Auto (DC type)*1					Auto (DC type)*1	
Angle of View (H x V) (1/3")	WIDE	100° 00' x 73° 45'	120° 00' x 91° 36'	100° 02' x 74° 03'	18° 08' x 13° 34'	97° 34' x 71° 47'*2	44° 21' x 33° 25'*2	
	TELE	35° 03' x 26° 18'	46° 26' x 34° 59'	23° 21' x 17° 36'	5° 35' x 4° 12'	28° 23' x 21° 18'*2	4° 38' x 3° 30'*2	
Angle of View (H x V) Aspect Ratio 16:9 (1/3")	WIDE	109° 50' x 59° 51'	129° 43' x 75° 23'	109° 33' x 60° 08'	19° 46' x 11° 04'	107° 12' x 58° 10'	48° 11' x 27° 20'	
	TELE	38° 11' x 21° 29'	50° 30' x 28° 38'	25° 31' x 14° 23'	6° 04' x 3° 26'	30° 55' x 17° 25'	2° 52' x 5° 02'	
Focus Range (From the Lens Front) (m)		∞ - 0.3			∞ - 0.8		∞ - 0.3	∞ - 1.5
Mass (g)		50	55	80	60	80	160	

* 1: The iris automatically closes when the camera is turned off. *2: 1/2" angle of view

* Each of the above products is also available in manual type. * Each of the above products is also available in long cable type (230 mm).

Vari-Focal **HD** Day Night

HD Vari-Focal (1.3M) **1.3MP**

YV3.3x15HR4A-SA2

3.3x Applicable camera (model) 1 2/3 1/2 1/3 1/4



HD Day Night
1.3MP

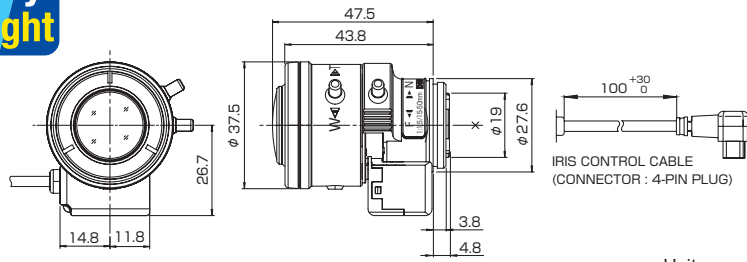

Unit : mm

Vari-Focal Long Focal DC Auto Iris DC Auto Iris Metal Mount ND Filter Long Cable Aspherical Lens Large Aperture Ratio RoHS Compliant
VARI **TELE** **DC** **CS-mt** **METAL** **ND** **230** **AT** **F1.5** **RoHS**

		YV3.3x15HR4A-SA2
Focal Length (mm)		15 - 50 (3.3x)
Iris Range		F1.5 - T360 (Equivalent to F360)
Operation	Zoom	Manual
	Focus	Manual
	Iris	Auto (DC type)*1
Angle of View (H x V) (1/3")	WIDE	18° 29' x 13° 45'
	TELE	5° 29' x 4° 09'
Angle of View (H x V) Aspect Ratio 16:9 (1/3")	WIDE	20° 13' x 11° 11'
	TELE	5° 57' x 3° 25'
Focus Range (From the Lens Front) (m)		∞ - 0.8
Mass (g)		50

* 1: The iris automatically closes when the camera is turned off.

YV10x5HR4A-SA2

10x Applicable camera (model) 1 2/3 1/2 1/3 1/4



HD Day Night
1.3MP

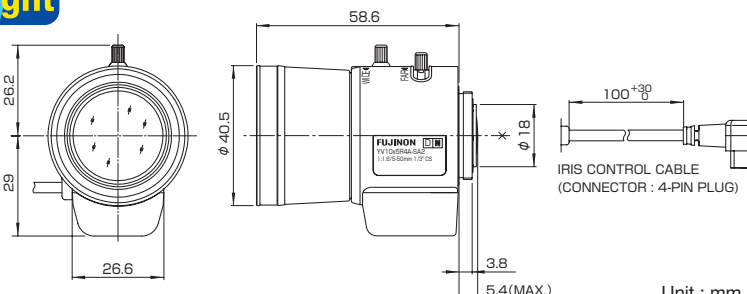

Unit : mm

Vari-Focal Wide Angle Telephoto Long Focal DC Auto Iris CS Mount Metal Mount ND Filter Long Cable Aspherical Lens Large Aperture Ratio RoHS Compliant
VARI **WIDE** **TELE** **DC** **CS-mt** **METAL** **ND** **230** **AT** **F1.6** **RoHS**

		YV10x5HR4A-SA2
Focal Length (mm)		5 - 50 (10x)
Iris Range		F1.6 - T360 (Equivalent to F360)
Operation	Zoom	Manual
	Focus	Manual
	Iris	Auto (DC type)*1
Angle of View (H x V) (1/3")	WIDE	51° 17' x 39° 36'
	TELE	5° 30' x 4° 07'
Angle of View (H x V) Aspect Ratio 16:9 (1/3")	WIDE	55° 35' x 31° 58'
	TELE	5° 47' x 3° 20'
Focus Range (From the Lens Front) (m)		∞ - 0.3
Mass (g)		85

* 1: The iris automatically closes when the camera is turned off.
* Each of the above products is also available in manual type.

Fixed Focal **HD** Day Night

HD Fixed Focal (5M) **5MP**

HF35SR4A-SA1L

Applicable camera (model) 1 2/3 1/2 1/3 1/4



HD Day Night
5MP

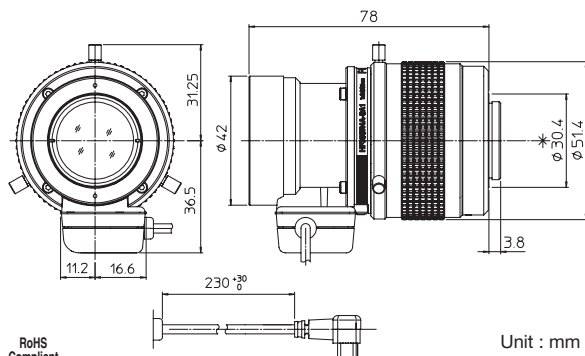

Unit : mm

Fixed Focal Telephoto Long Focal DC Auto Iris C Mount Metal Mount ND Filter RoHS Compliant
FIXED **TELE** **DC** **C-mt** **METAL** **ND** **RoHS**

		HF35SR4A-SA1L
Focal Length (mm)		35
Iris Range		F2.0 - T360
Operation	Focus	Manual
	Iris	Auto (DC type)*1
Angle of View(H x V)		2/3" 14° 20' x 10° 46'
Angle of View(H x V) Aspect Ratio 16:9		2/3" 15° 36' x 8° 48'
Focus Range (From the Lens Front) (m)		∞ - 0.75
Mass (g)		270

* 1: The iris automatically closes when the camera is turned off.
* Each of the above products is also available in manual type.

HF50SR4A-SA1L

Applicable camera (model) 1 2/3 1/2 1/3 1/4



HD Day Night
5MP

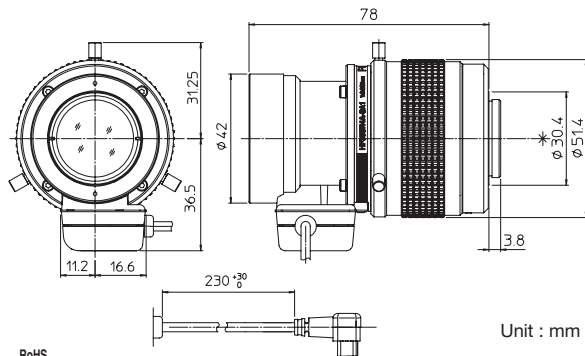

Unit : mm

Fixed Focal Telephoto Long Focal DC Auto Iris C Mount Metal Mount ND Filter RoHS Compliant
FIXED **TELE** **DC** **C-mt** **METAL** **ND** **RoHS**

		HF50SR4A-SA1L
Focal Length (mm)		50
Iris Range		F2.8 - T360
Operation	Focus	Manual
	Iris	Auto (DC type)*1
Angle of View(H x V)		2/3" 10° 03' x 7° 33'
Angle of View(H x V) Aspect Ratio 16:9		2/3" 10° 57' x 6° 10'
Focus Range (From the Lens Front) (m)		∞ - 1.0
Mass (g)		260

* 1: The iris automatically closes when the camera is turned off.
* Each of the above products is also available in manual type.

Fish-Eye

FE185C046HA-1

Applicable camera (model) 1 2/3 1/2 1/3 1/4



Fixed Focal **FIXED** Fish-Eye **185°** Manual Iris **MANUAL** C Mount **C-mt** Metal Mount **METAL** Large Aperture Ratio **F1.4** RoHS Compliant **RoHS**

Fish-Eye Lens View



FE185C057HA-1

Applicable camera (model) 1 2/3 1/2 1/3 1/4

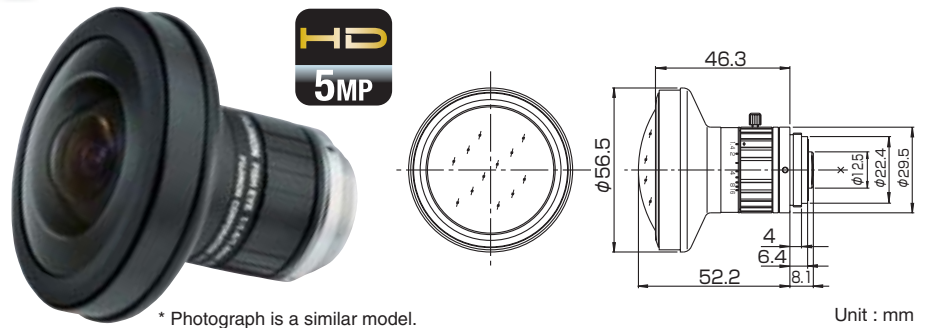

* Photograph is a similar model.

Fixed Focal **FIXED** Fish-Eye **185°** Manual Iris **MANUAL** C Mount **C-mt** Metal Mount **METAL** Large Aperture Ratio **F1.4** RoHS Compliant **RoHS**

Fish-Eye Lens View

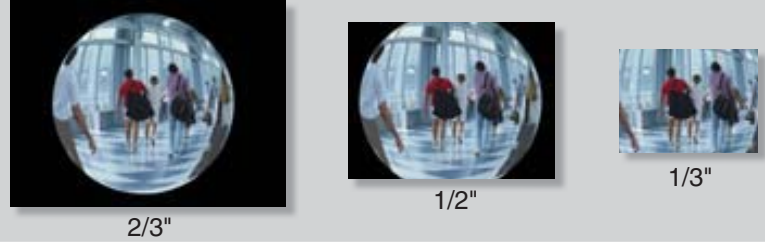

FE185C086HA-1

Applicable camera (model) 1 2/3 1/2 1/3 1/4

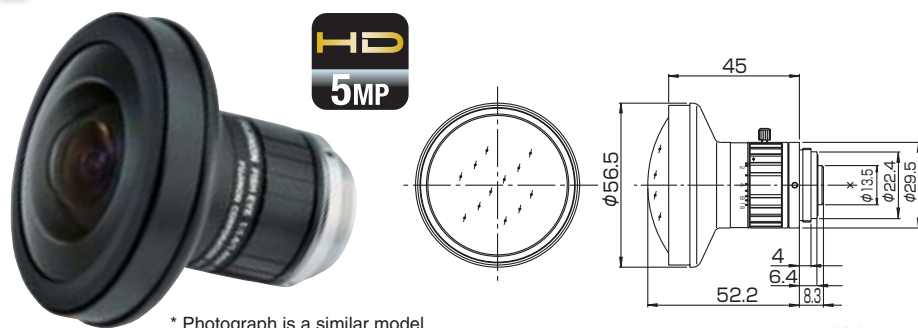

* Photograph is a similar model.

Fixed Focal **FIXED** Fish-Eye **185°** Manual Iris **MANUAL** C Mount **C-mt** Metal Mount **METAL** RoHS Compliant **RoHS**

Fish-Eye Lens View

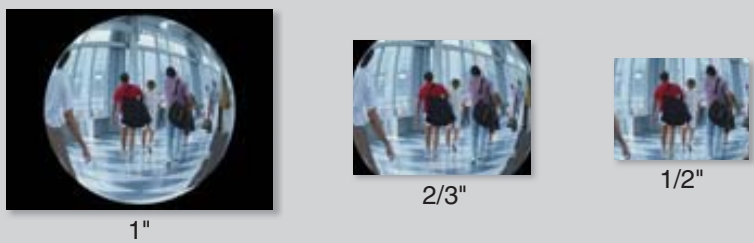

YV2.2x1.4A-SA2

2.2x Applicable camera (model) 1 2/3 1/2 1/3 1/4



IRIS CONTROL CABLE (CONNECTOR : 4-PIN PLUG)

Unit : mm

Vari-Focal **VARI** Fish-Eye **185°** DC Auto Iris **DC** CS Mount **CS-mt** ND Filter **ND** Long Cable **230** Large Aperture Ratio **F1.4** RoHS Compliant **RoHS**

Fish-Eye Lens View



	FE185C046HA-1	FE185C057HA-1	FE185C086HA-1	YV2.2x1.4A-SA2
Focal Length	1.4	1.8	2.7	1.4 - 3.1 (2.2x)
Iris Range	F1.4 - F16			F1.4 - T360 (Equivalent to F360)
Operation	Zoom	-		
	Focus	Fixed		
	Iris	Manual		
Angle of View (H x V)	WIDE	185° x 185° (φ 4.6mm) (1/2")	185° x 185° (φ 5.7mm) (2/3")	185° x 185° (φ 3.45mm) (1/3")
	TELE			94° 47' x 69° 26' (1/3")
Focus Range (From the Lens Front) (m)	∞ - 0.1		∞ - 0.2	
Mass (g)	140	135	160	80

* 1: The iris automatically closes when the camera is turned off.

* YV2.2x1.4A-SA2 is also available in a long cable type (230 mm) or manual type.

Vari-Focal

YV2.7x2.9LR4D-SA2

2.7x Applicable camera (model) 1 2/3 1/2 1/3 1/4



Day
Night

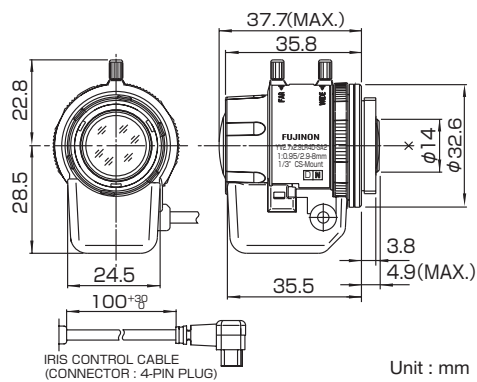

Unit : mm

Vari-Focal Wide Angle DC Auto Iris CS Mount Metal Mount ND Filter Long Cable Aspherical Lens Large Aperture Ratio RoHS Compliant
VARI **WIDE** **DC** **CS-mt** **METAL** **ND** **230** **AT** **F0.95** **RoHS**

YV5x2.7LR4B-SA2

5x Applicable camera (model) 1 2/3 1/2 1/3 1/4



Day
Night

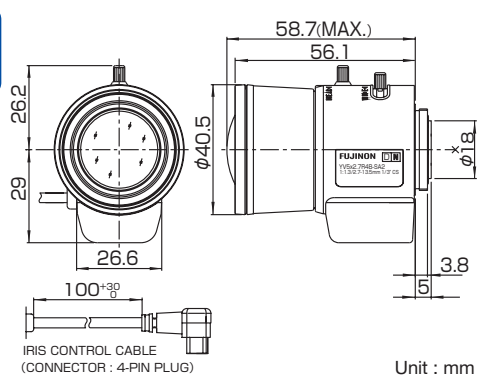

Unit : mm

Vari-Focal Wide Angle Telephoto Long Focal DC Auto Iris CS Mount Metal Mount ND Filter Long Cable Aspherical Lens Large Aperture Ratio RoHS Compliant
VARI **WIDE** **TELE** **DC** **CS-mt** **METAL** **ND** **230** **AT** **F1.3** **RoHS**

DV5x3.6R4B-SA2

5x Applicable camera (model) 1 2/3 1/2 1/3 1/4



Day
Night

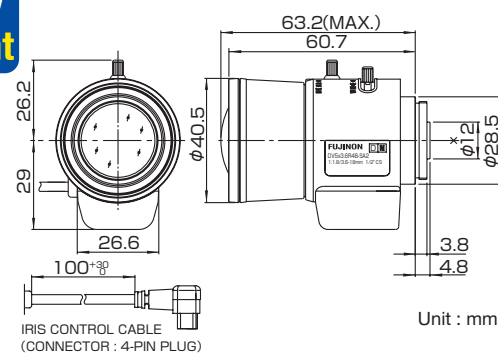

Unit : mm

Vari-Focal Wide Angle Telephoto Long Focal DC Auto Iris CS Mount Metal Mount ND Filter Long Cable Aspherical Lens RoHS Compliant
VARI **WIDE** **TELE** **DC** **CS-mt** **METAL** **ND** **230** **AT** **RoHS**

Applicable to 1/2

	YV2.7x2.9LR4D-SA2	YV5x2.7LR4B-SA2	DV5x3.6R4B-SA2
Focal Length (mm)	2.9 - 8 (2.7x)	2.7 - 13.5 (5x)	3.6 - 18 (5x)
Iris Range	F0.95 - T360 (Equivalent to F360)	F1.3 - T360 (Equivalent to F360)	F1.8 - T360 (Equivalent to F360)
Operation	Zoom	Manual	Manual
	Focus	Manual	Manual
	Iris	Auto (DC type)*1	Auto (DC type)*1
Angle of View (H x V) (1/3")	WIDE	94° 37' x 69° 30'	95° 54' x 72° 24'
	TELE	35° 18' x 26° 26'	20° 37' x 15° 30'
Focus Range (From the Lens Front) (m)	∞ - 0.3		∞ - 0.3
Mass (g)	45	70	75

* 1: The iris automatically closes when the camera is turned off.

* Each of the above products is also available in manual type.

* Each of the above products is also available in long cable type (230 mm).

YV2.8x2.8LA-SA2

2.8x Applicable camera (model) 1 2/3 1/2 1/3 1/4

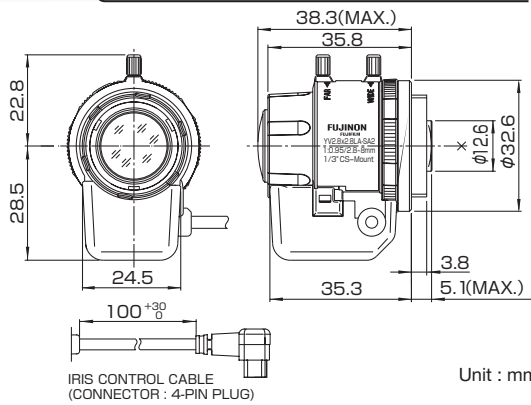

Unit : mm

Vari-Focal Wide Angle DC Auto Iris CS Mount Metal Mount ND Filter Long Cable Aspherical Lens Large Aperture Ratio RoHS Compliant
VARI **WIDE** **DC** **CS-mt** **METAL** **ND** **230** **AT** **F0.95** **RoHS**

YV10x5B-SA2

10x Applicable camera (model) 1 2/3 1/2 1/3 1/4

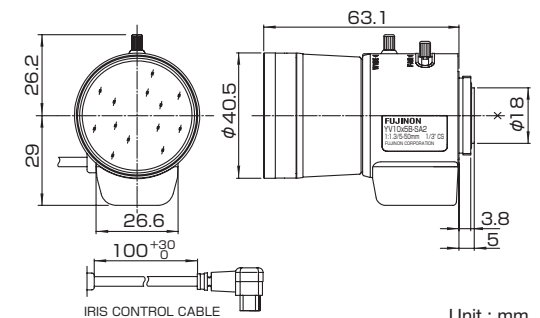

Unit : mm

Vari-Focal Wide Angle Telephoto Long Focal DC Auto Iris CS Mount Metal Mount ND Filter Long Cable Aspherical Lens Large Aperture Ratio RoHS Compliant
VARI **WIDE** **TELE** **DC** **CS-mt** **METAL** **ND** **230** **AT** **F1.3** **RoHS**

Applicable to 1/2

	YV2.8x2.8LA-SA2	YV10x5B-SA2	DV10x7B-SA2
Focal Length (mm)	2.8 - 8 (2.8x)	5 - 50 (10x)	7 - 70 (10x)
Iris Range	F0.95 - T360 (Equivalent to F360)	F1.3 - T360 (Equivalent to F360)	F1.8 - T360 (Equivalent to F360)
Operation	Zoom	Manual	Manual
	Focus	Manual	Manual
	Iris	Auto (DC type)*1	Auto (DC type)*1
Angle of View (H x V) (1/3")	WIDE	99° 52' x 73° 17'	50° 01' x 38° 12'
	TELE	35° 14' x 26° 24'	5° 24' x 4° 05'
Focus Range (From the Lens Front) (m)	∞ - 0.3		∞ - 0.3
Mass (g)	45	100	100

* 1: The iris automatically closes when the camera is turned off.

* Each of the above products is also available in manual type.

* Each of the above products is also available in long cable type (230 mm).

DV10x7B-SA2

10x Applicable camera (model) 1 2/3 1/2 1/3 1/4

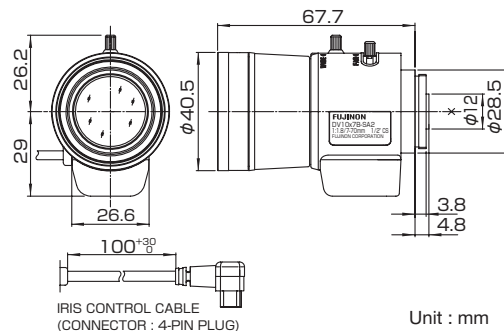

Unit : mm

Vari-Focal Wide Angle Telephoto Long Focal DC Auto Iris CS Mount Metal Mount ND Filter Long Cable Aspherical Lens RoHS Compliant
VARI **WIDE** **TELE** **DC** **CS-mt** **METAL** **ND** **230** **AT** **RoHS**

* To be discontinued when stock runs out.

* Photograph is a similar model.

Zoom

HD Zoom (2000mm 2M)

D60x16.7SR4 Series

60x Applicable camera (model) 1 2/3 1/1.8 1/2 1/3 1/4

HD 2MP Day Night VISIBLE LIGHT CUT Applicable to 1/1.8

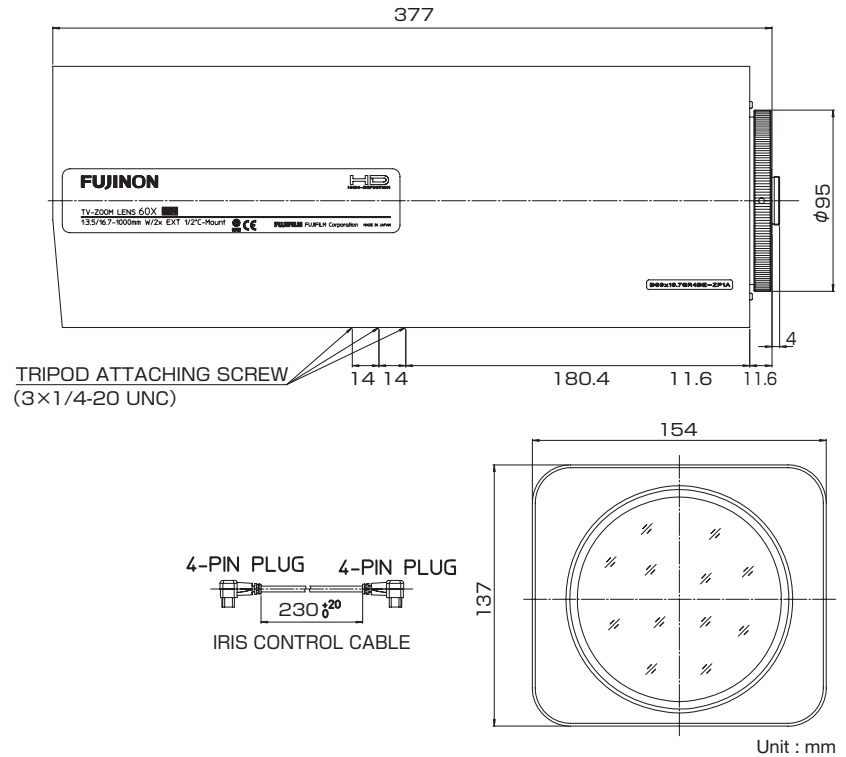

Zoom Motor Drive Telephoto Long Focal Auto Focus Optical Anti-Vibration DC Auto Iris C Mount Metal Mount Potentiometer ND Filter Extender PC Control Full Servo RoHS Compliant

ZOOM MOTOR DRIVE TELE AF OS-TECH DC C-mt METAL PRESET ND 2x PC SERVO RoHS

-ZPIA -ZPIC -ZPIC -ZPIC -V21 -ZPIA -ZPIC -ZPIC

	NEW	Coming Soon	Coming Soon
	D60x16.7SR4DE-V21	D60x16.7SR4DE-ZP1A (AF)	D60x16.7SR4FE-ZP1C (AF and Anti-Vibration)

Focal Length (mm)	1x	16.7 - 1000	16.7 - 1000	
	2x	33.4 - 2000	33.4 - 2000	
Iris Range	1x	F3.5 - F16	F3.5 - F16	
	2x	F7.0 - F32	F7.0 - F32	
Filter		ND (1/8, 1/64), Visible Light Cut	ND (1/8, 1/64), Visible Light Cut	
Operation	Zoom	Motor Drive	Motor Drive	
	Focus	Motor Drive	Motor Drive	
	Iris	Auto (DC type) or Remote*1	Auto (DC type) or Remote*1	
AF		N/A	Available (with analog camera)	
Optical Anti-Vibration		N/A	Available	
Angle of View (H x V) (4:3) (mm)	1/1.8"	1x WIDE	23° 4' x 17° 40'	23° 5' x 17° 41'
		TELE	0° 25' x 0° 19'	0° 25' x 0° 19'
		2x WIDE	11° 45' x 8° 53'	11° 46' x 8° 54'
	1/2"	1x WIDE	20° 51' x 15° 54'	20° 53' x 15° 55'
		TELE	0° 22' x 0° 17'	0° 22' x 0° 17'
		2x WIDE	10° 34' x 7° 58'	10° 35' x 7° 59'
Angle of View (H x V) (16:9) (mm)	1/1.8"	1x WIDE	24° 53' x 14° 34'	24° 56' x 14° 34'
		TELE	0° 27' x 0° 15'	0° 27' x 0° 15'
		2x WIDE	12° 45' x 7° 17'	12° 47' x 7° 18'
	1/2"	1x WIDE	22° 33' x 13° 5'	22° 35' x 13° 6'
		TELE	0° 24' x 0° 14'	0° 24' x 0° 14'
		2x WIDE	11° 28' x 6° 32'	11° 30' x 6° 32'
	TELE	0° 12' x 0° 7'	0° 12' x 0° 7'	
Focus Range (From the Lens Front) (m)		∞ - 5	∞ - 5	
Object Dimensions at M.O.D.(H x V) (4:3) (mm)	1/1.8"	1x WIDE	1972 x 1503	1975 x 1504
		TELE	35 x 27	35 x 27
		2x WIDE	995 x 27	998 x 753
	1/2"	1x WIDE	1780 x 1351	1782 x 1353
		TELE	32 x 24	32 x 24
		2x WIDE	895 x 675	896 x 676
Object Dimensions at M.O.D.(H x V) (16:9) (mm)	1/1.8"	1x WIDE	2133 x 1236	2137 x 1237
		TELE	38 x 22	38 x 22
		2x WIDE	1081 x 616	1084 x 617
	1/2"	1x WIDE	1929 x 1110	1931 x 1111
		TELE	34 x 20	34 x 20
		2x WIDE	972 x 553	974 x 553
	TELE	17 x 10	17 x 10	
Back Focal Distance (in air) (mm)		24.92	24.85	
Filter Thread (mm)		M112 x 0.75	M112 x 0.75	
Mass (kg)		6.3	TBA	
Wiring Diagram		See P. 19	-	

*1: For details on the Iris-Remote connection, see the relevant Technical Reference (Page 23).

HD Zoom (320mm/500mm 1.3M)

D32x10HR4D Series

32x Applicable camera (model) 1 2/3 1/2 1/3 1/4

D32x15.6HR4D Series

HD Day
1.3MP Night

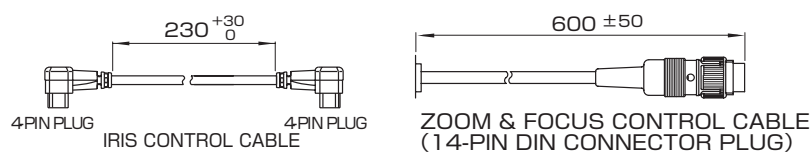
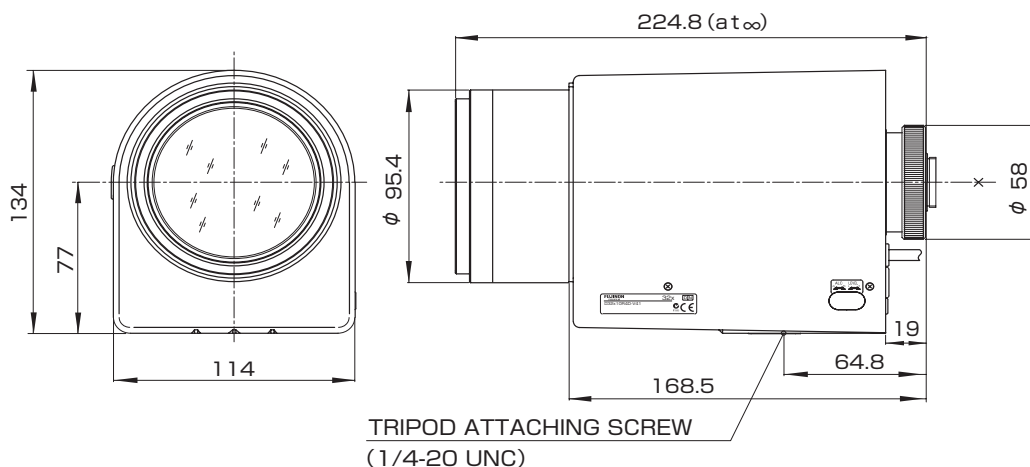

Unit : mm

- Zoom
 - Motor Drive
 - Telephoto Long Focal
 - Wide Angle
 - DC Auto Iris
 - Video Auto Iris
 - Iris-Remote
 - C Mount
 - Metal Mount
 - Potentiometer
 - ND Filter
 - RoHS Compliant
- ZOOM
MOTOR DRIVE
TELE
WIDE
DC
VIDEO
IRIS-REMOTE
C-mt
METAL
PRESET
ND
RoHS
- YE1
-V41
-V41

	D32x10HR4D-V41	D32x10HR4D-YE1	D32x15.6HR4D-V41	D32x15.6HR4D-YE1
Focal Length (mm)	10 - 320 (32x)		15.6 - 500 (32x)	
Iris Range	F2.5 - T1500 (Equivalent to F1500)		F3.9 - T1500 (Equivalent to F1500)	
Operation	Zoom	Motor Drive		
	Focus	Motor Drive		
	Iris	Auto (Video Type) or Remote*1 *2	Auto (DC Type)*1	Auto (Video Type) or Remote*1 *2
Angle of View (H x V) (4:3)	1/2"	WIDE	35° 29' x 26° 59'	23° 11' x 17° 30'
		TELE	1° 09' x 0° 52'	0° 44' x 0° 33'
Angle of View (H x V) (16:9)	1/2"	WIDE	38° 26' x 22° 11'	25° 11' x 14° 19'
		TELE	1° 15' x 0° 42'	0° 48' x 0° 27'
Focus Range (From the Lens Front) (m)	∞ - 3			
Object Dimensions at M.O.D.(H x V) (4:3) (mm)	1/2"	WIDE	1746 x 1310	1152 x 864
		TELE	57 x 43	37 x 28
Object Dimensions at M.O.D. (H x V) (16:9) (mm)	1/2"	WIDE	1890 x 1086	1253 x 709
		TELE	62 x 35	41 x 23
Back Focal Distance (in air) (mm)	22.70		44.92	
Exit Pupil Position (From Image Plane) (mm)	- 53		- 75	
Filter Thread (mm)	M82 x 0.75		M82 x 0.75	
Mass (kg)	2.5		2.7	
Wiring Diagram	See P. 19	See P. 19	See P. 19	See P. 19

*1: The iris automatically closes when the camera is turned off.

*2: For details on the Iris-Remote connection, see the relevant Technical Reference (Page 23).

Zoom

HD Zoom (63mm 1.3M)

D8x7.8HA Series

8x Applicable camera (model) 1 2/3 1/2 1/3 1/4



HD
1.3MP

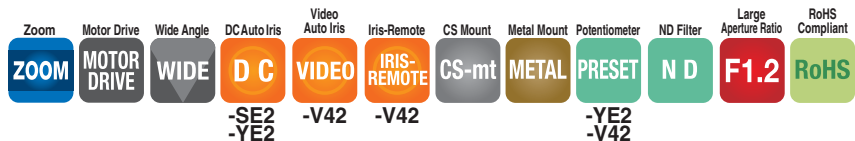
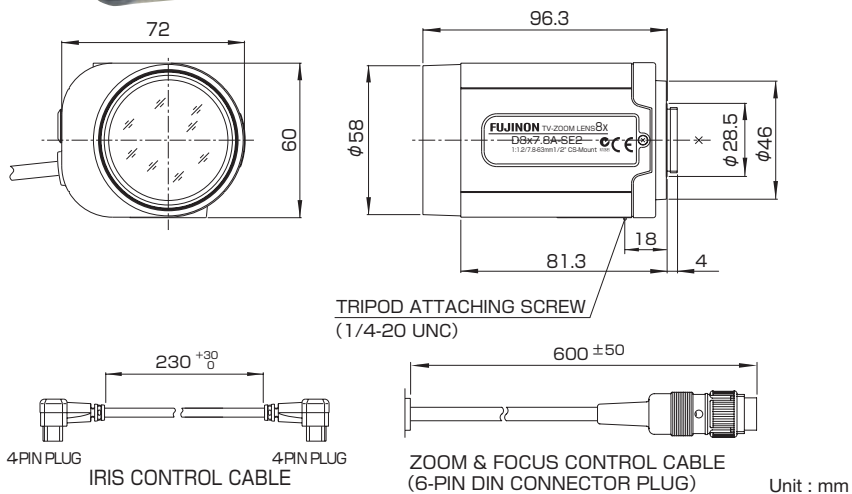

		D8x7.8HA-SE2	D8x7.8HA-YE2	D8x7.8HA-V42
Focal Length (mm)		7.8 - 63 (8x)		
Iris Range		F1.2 - T400(Equivalent to F400)		
Operation	Zoom	Motor Drive		
	Focus	Motor Drive		
	Iris	Auto (DC type)*1	Auto (Video Type) or Remote*1	
Angle of View (H x V)	1/2"	WIDE	44° 37' x 34° 12'	
		TELE	5° 49' x 4° 22'	
Angle of View (H x V)(16:9)	1/2"	WIDE	48° 10' x 28° 14'	
		TELE	6° 20' x 3° 34'	
Focus Range (From the Lens Front) (m)		∞ - 1.2		
Object Dimensions at M.O.D. (H x V) (mm)	1/2"	WIDE	944 x 708	
		TELE	117 x 88	
Back Focal Distance (in air) (mm)		14.00		
Exit Pupil Position (From Image Plane) (mm)		- 55		
Filter Thread (mm)		M55 x 0.75		
Mass (g)		400		
Coil Resistance		Drive Coil 200Ω	Damping Coil 700Ω	-
Power Consumption		22mA (Max.) at DC 4V		
Wiring Diagram		See P. 19	See P. 20	See P. 20

* 1: The iris automatically closes when the camera is turned off.

Zoom (1500mm SD)

D60x12.5BE-V41

60x Applicable camera (model) 1 2/3 1/2 1/3 1/4

D60x12.5R3DE Series

Day
Night

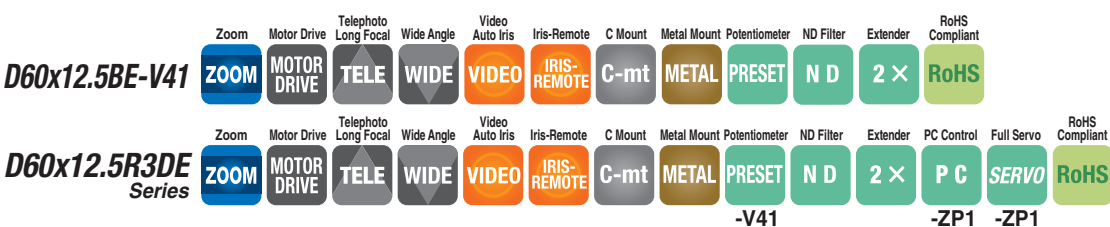
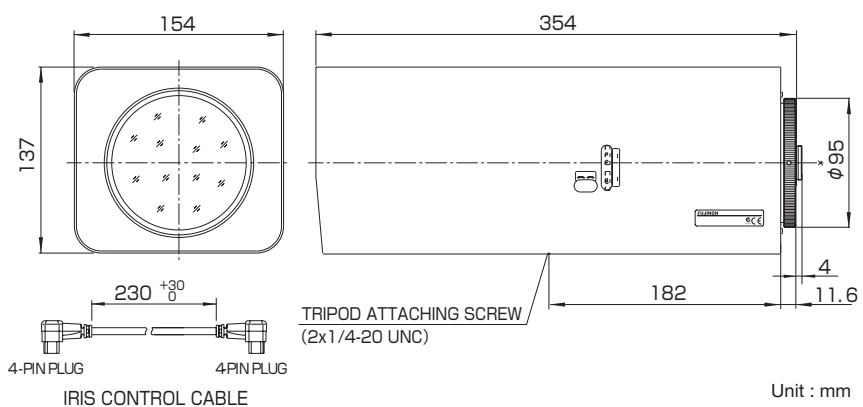

		D60x12.5BE-V41	D60x12.5R3DE-V41	D60x12.5R3DE-ZP1
Focal Length (mm)	1x	12.5 - 750 (60x)		
	2x	25 - 1500 (60x)		
Iris Range	1x	F3.8 - T3000(Equivalent to F3000)		
	2x	F7.6 - T3000(Equivalent to F3000)		
Operation	Zoom	Motor Drive	Servo Control	
	Focus	Motor Drive	Servo Control	
	Iris	Auto (Video type) or Remote*1 *2		Auto (Video Type) or Remote*1 *2 or Servo Control
Angle of View (H x V)	1/2"	1x	WIDE	28° 43' x 21° 44'
			TELE	0° 29' x 0° 22'
	2x	WIDE	14° 35' x 10° 58'	
		TELE	0° 15' x 0° 11'	
Focus Range (From the Lens Front) (m)		∞ - 5		
Object Dimensions at M.O.D. (H x V)(mm)	1/2"	1x	WIDE	2465 x 1849
			TELE	41 x 31
	2x	WIDE	1233 x 924	
		TELE	21 x 15	
Back Focal Distance (in air) (mm)		53.23		
Exit Pupil Position (From Image Plane) (mm)		- 77		
Filter Thread (mm)		M107 x 1		
Extender		2x		
Mass (kg)		5.1	5.2	
Wiring Diagram		See P. 20	See P. 20	See P. 21

* 1: The iris automatically closes when the camera is turned off.

* 2: For details on the Iris-Remote connection, see the relevant Technical Reference (Page 23).

Zoom (2200mm SD)

C55x20P-EP1B

55x Applicable camera (model) 1 2/3 1/2 1/3 1/4

C55x20R2Q-EP1B

Day
Night

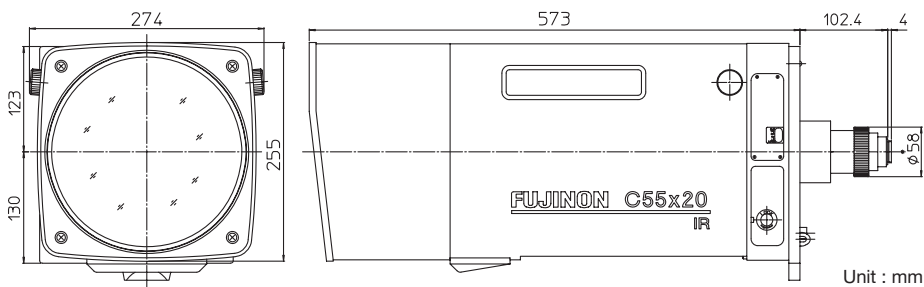

		C55x20P-EP1B	C55x20R2Q-EP1B
Focal Length (mm)	1x	20 - 1100	
	2x	40 - 2200	
Iris Range	1x	F3.0 - T1500 (Equivalent to F1500)	
	2x	F6.0 - T3000 (Equivalent to F3000)	
Operation	Zoom	Servo Control	
	Focus	Servo Control	
	Iris	Auto (Video Type) or Servo Control	
Angle of View (H x V)	1"	WIDE	35° 29' x 26° 59'
		TELE	0° 40' x 0° 30'
	2"	WIDE	18° 10' x 13° 41'
		TELE	0° 20' x 0° 15'
Focus Range (From the Lens Front) (m)		∞ - 2.4	
Object Dimensions at M.O.D. (H x V) (mm)	1"	WIDE	1400 x 1051
		TELE	25 x 19
	2"	WIDE	700 x 525
		TELE	13 x 10
Back Focal Distance (in air) (mm)		28.04	
Exit Pupil Position (From Image Plane) (mm)	1x	- 163	
	2x	- 131	
Extender		2x	
Mass (kg)		21	
Control Unit		CRD-40 (Option)	

[Electrical Specification] Power Supply: DC 12V (DC 11V to 16V) Power Consumption: 2.1A (Max.)

	Zoom	Focus	Iris	Extender
Control Signal	TELE: 2.5V WIDE: 7.5V	NEAR: 2.5V FAR : 7.5V	AUTO / VIDEO (1Vp-p)/ REMOTE / OPEN :7V, CLOSE:2V	1x : ∞ 2x : +V
Power Consumption	670mA (Max.)	670mA (Max.)	100mA (Max.)	220mA (Max.)
Operating Time	1s. (Max.)	1s. (Max.)	1s. (Max.)	1s. (Max.)

* C55x13.5P-EP1B and C55x13.5R-EP1B are also available.

Zoom (506mm SD)

C22x23 Series

22x Applicable camera (model) 1 2/3 1/2 1/3 1/4

C22x23R2D Series

Day
Night

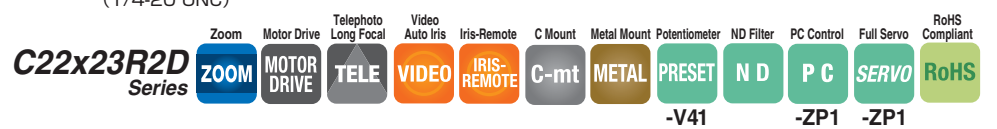
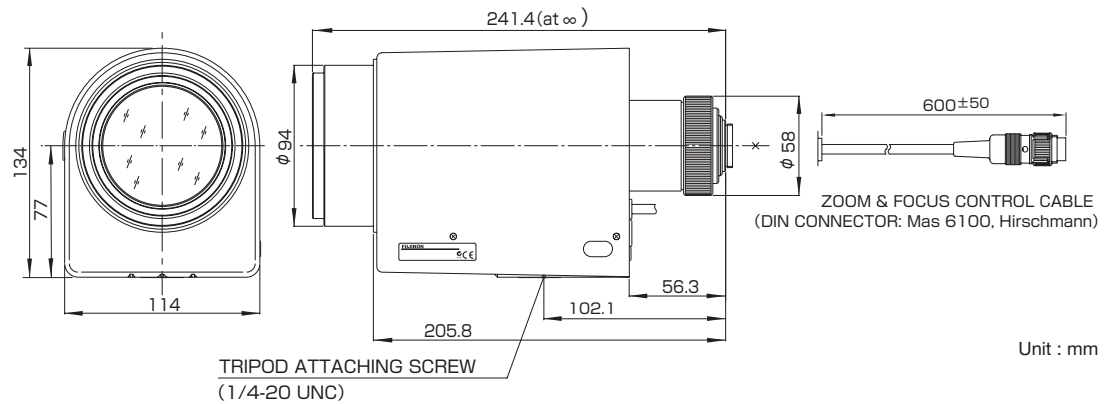

		C22x23A-M41	C22x23B-V41	C22x23R2D-V41	C22x23R2D-ZP1
Focal Length		23 - 506 (22x)			
Iris Range		F3.1 - F22 · Close		F3.1 - T3000 (Equivalent to F3000)	
Operation	Zoom	Motor Drive		Servo Control	
	Focus	Motor Drive		Servo Control	
	Iris	Motor Drive	Auto (Video Type) or Remote* ¹		Auto (Video Type) or Remote* ¹ or Servo Control
Angle of View (H x V)	1"	WIDE	31° 06' x 23° 35'		
		TELE	1° 27' x 1° 05'		
Focus Range (From the Lens Front) (m)		∞ - 3			
Object Dimensions at M.O.D. (H x V)(mm)	1"	WIDE	1611 x 1208		
		TELE	73 x 55		
Back Focal Distance (in air) (mm)		39.54			
Exit Pupil Position (From Image Plane) (mm)		- 64			
Filter Thread (mm)		M82 x 0.75			
Mass (kg)		2.4			
Wiring Diagram		See P. 21	See P. 22	See P. 21	See P. 21

* 1: For details on the Iris-Remote connection, see the relevant Technical Reference (Page 23).

For detailed specifications, see the following website: http://www.fujifilm.com/products/optical_devices/cctv/security/

Zoom

Zoom (374mm SD)

C22x17 Series

22x Applicable camera (model) 1 2/3 1/2 1/3 1/4

C22x17R2D-V41

Day Night



* Photograph is a similar model.

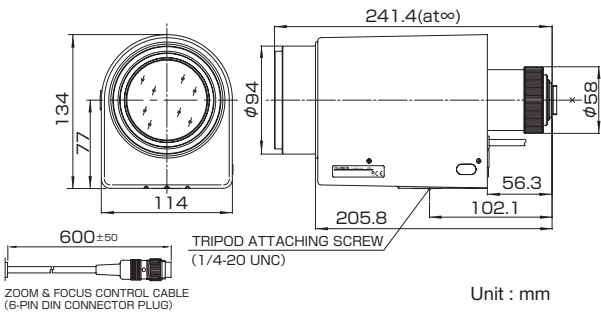

Unit : mm

	C22x17A-M41	C22x17B-S41	C22x17B-Y41	C22x17R2D-V41
Focal Length	17 - 374 (22x)			
Iris Range	F2.3 - F22 · Close	F2.3 - T3000 (Equivalent to F3000)		
Operation	Zoom	Motor Drive		
	Focus	Motor Drive		
	Iris	Motor Drive	Auto (Video Type)	Auto (Video Type) or Remote*1
Angle of View(H × V)	1"	WIDE	41° 16' x 31° 32'	
		TELE	1° 58' x 1° 28'	
Focus Range (From the Lens Front) (m)	∞ - 3			
Object Dimensions at M.O.D.(H × V)(mm)	1"	WIDE	2178 x 1633	
		TELE	99 x 74	
Back Focal Distance (in air) (mm)	66.93	67.38		
Exit Pupil Position (From Image Plane) (mm)	- 127			
Filter Thread (mm)	M82 x 0.75			
Mass (kg)	2.3	2.5		2.3
Wiring Diagram	See P. 21	See P. 22	See P. 22	See P. 21

* 1: For details on the Iris-Remote connection, see the relevant Technical Reference (Page 23).

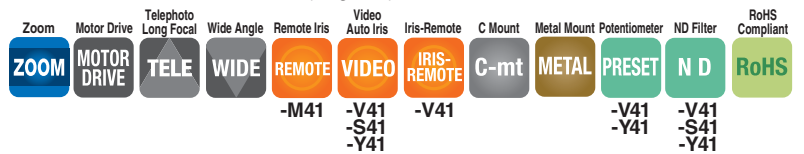

Zoom (253mm SD)

H22x11.5 Series

22x Applicable camera (model) 1 2/3 1/2 1/3 1/4

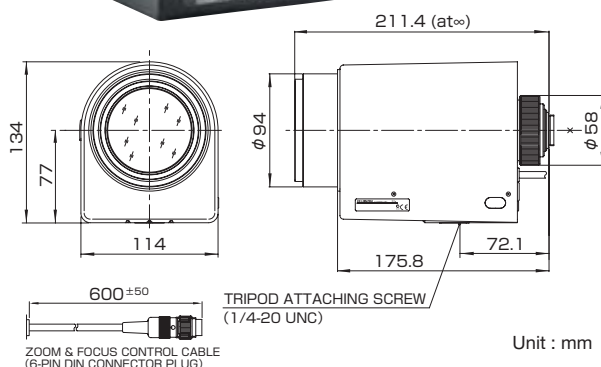

Unit : mm

	H22x11.5A-M41	H22x11.5B-S41	H22x11.5B-Y41	
Focal Length	11.5 - 253 (22x)			
Iris Range	F1.6 - F22 · Close	F1.6 - T2000 (Equivalent to F2000)		
Operation	Zoom	Motor Drive		
	Focus	Motor Drive		
	Iris	Motor Drive	Auto (Video Type)	
Angle of View(H × V)	2/3"	WIDE	41° 52' x 32° 01'	
		TELE	2° 00' x 1° 30'	
Focus Range (From the Lens Front) (m)	∞ - 3			
Object Dimensions at M.O.D.(H × V)(mm)	2/3"	WIDE	2213 x 1660	
		TELE	101 x 75	
Back Focal Distance (in air) (mm)	35.95	36.16		
Exit Pupil Position (From Image Plane) (mm)	- 103			
Filter Thread (mm)	M82 x 0.75			
Mass (kg)	2.3			
Wiring Diagram	See P. 21	See P. 22	See P. 22	

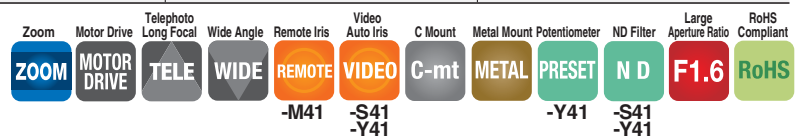

H22x11.5R2D Series

22x Applicable camera (model) 1 2/3 1/2 1/3 1/4



Day Night

* Photograph is a similar model.

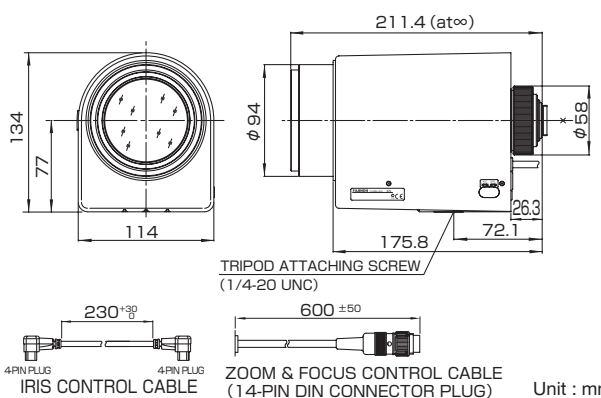

Unit : mm

	H22x11.5R2D-V41	H22x11.5R2D-ZP1	
Focal Length	11.5 - 253 (22x)		
Iris Range	F1.6 - T2000 (Equivalent to F2000)		
Operation	Zoom	Servo Control	
	Focus	Servo Control	
	Iris	Auto (Video Type) or Remote*1 or Servo Control	
Angle of View(H × V)	2/3"	WIDE	41° 52' x 32° 01'
		TELE	2° 00' x 1° 30'
Focus Range (From the Lens Front) (m)	∞ - 3		
Object Dimensions at M.O.D.(H × V)(mm)	2/3"	WIDE	2213 x 1660
		TELE	101 x 75
Back Focal Distance (in air) (mm)	36.16		
Exit Pupil Position (From Image Plane) (mm)	- 103		
Filter Thread (mm)	M82 x 0.75		
Mass (kg)	2.5		
Wiring Diagram	See P. 21	See P. 21	

* 1: For details on the Iris-Remote connection, see the relevant Technical Reference (Page 23).

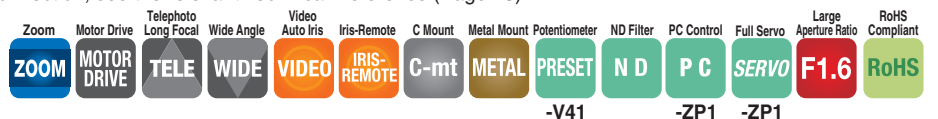

Vari-Focal
HD Vari-Focal (3M)

Vari-Focal
HD Vari-Focal (1.3M)

Fixed Focal
HD Fixed Focal (5M)

Fish-Eye

Vari-Focal

Zoom

Fixed Focal

Zoom Lens
Wiring

Technical
Information

Zoom (200mm SD)

D22x9.1B Series

22x Applicable camera (model) 1 2/3 1/2 1/3 1/4



* Photograph is a similar model.

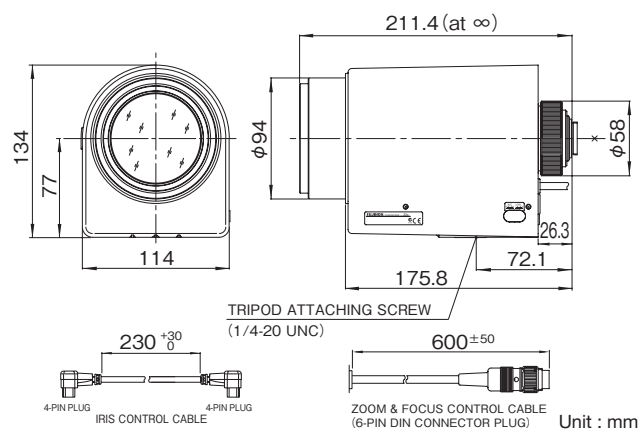

		D22x9.1B-S41	D22x9.1B-Y41
Focal Length		9.1 - 200 (22x)	
Iris Range		F1.2 - T1500 (Equivalent to F1500)	
Operation	Zoom	Motor Drive	
	Focus	Motor Drive	
	Iris	Auto (Video Type)	
Angle of View(HxV)	1/2" WIDE	38° 45' x 29° 33'	
	TELE	1° 50' x 1° 23'	
Focus Range (From the Lens Front) (m)		∞ - 3	
Object Dimensions at M.O.D.(HxV)(mm)	1/2" WIDE	2034 x 1526	
	TELE	93 x 69	
Back Focal Distance (in air) (mm)		23.93	
Exit Pupil Position (From Image Plane) (mm)		-676	
Filter Thread (mm)		M82 x 0.75	
Mass (kg)		2.3	
Wiring Diagram		See P.22	See P.22

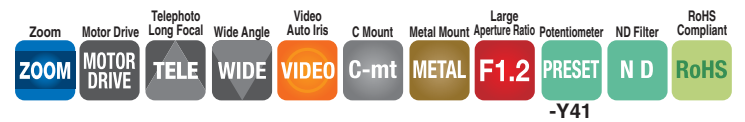

-Y41

Zoom (72mm/96mm SD)

Y12x6A Series

12x Applicable camera (model) 1 2/3 1/2 1/3 1/4

D12x8A Series

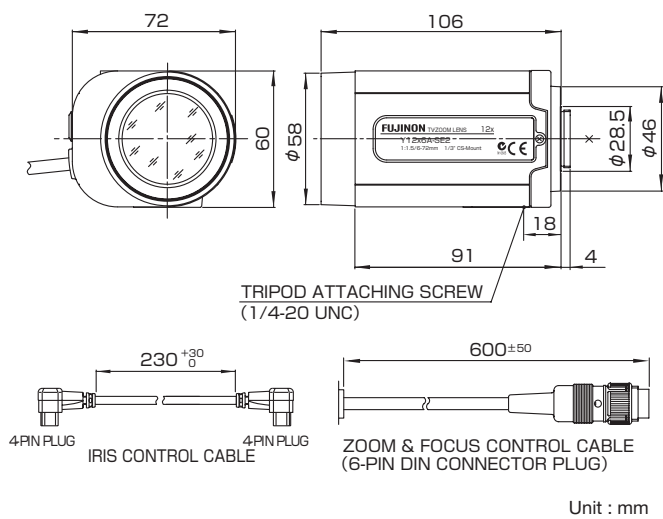

		Applicable to 1/3	Applicable to 1/3	Applicable to 1/2	Applicable to 1/2	
		Y12x6A-SE2	Y12x6A-YE2	D12x8A-SE2	D12x8A-YE2	
Focal Length		6 - 72 (12x)		8 - 96 (12x)		
Iris Range		F1.5 - T400 (Equivalent to F400)		F2.0 - T400 (Equivalent to F400)		
Operation	Zoom	Motor Drive		Motor Drive		
	Focus	Motor Drive		Motor Drive		
	Iris	Auto (DC type)*1		Auto (DC type)*1		
Angle of View(H x V)	1/2"	WIDE	-	43° 36' x 33° 24'		
		TELE	-	3° 49' x 2° 52'		
	1/3"	WIDE	43° 36' x 33° 24'		33° 24' x 25° 22'	
		TELE	3° 49' x 2° 52'		2° 52' x 2° 09'	
Focus Range (From the Lens Front) (m)		∞ - 1.3		∞ - 1.3		
Object Dimensions at M.O.D.(H x V)(mm)	1/2"	WIDE	-	1003 x 753		
		TELE	-	84 x 63		
	1/3"	WIDE	1003 x 753		752 x 565	
		TELE	84 x 63		63 x 47	
Back Focal Distance (in air) (mm)		11.69		16.22		
Exit Pupil Position (From Image Plane) (mm)		- 6028		- 51		
Filter Thread (mm)		M55 x 0.75		M55 x 0.75		
Mass (g)		330	350	330	350	
Coil Resistance		Drive Coil 180Ω Damping Coil 720Ω				
Power Consumption		22mA (Max.) at DC 4V		22mA (Max.) at DC 4V		
Wiring Diagram		See P.19	See P.20	See P.19	See P.20	

* 1: The iris automatically closes when the camera is turned off.

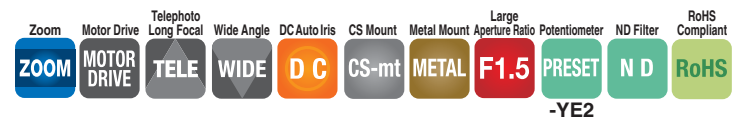

-YE2

Zoom

Zoom (85mm/114mm SD 3CCD)

S17x6.6DA-R11

17x Applicable camera (model) 1 2/3 1/2 1/3 1/4



* Photograph is a similar model.

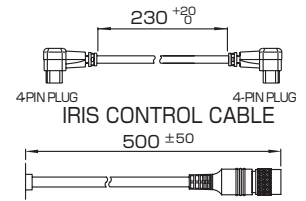
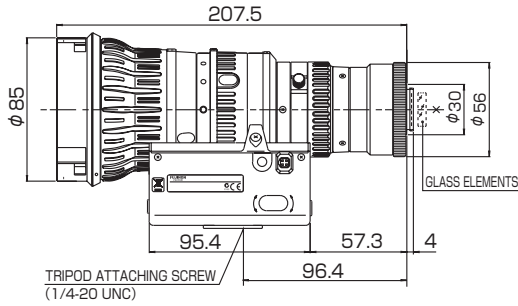
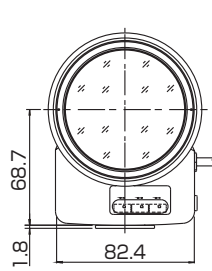

CONTROL CABLE (CONNECTOR: HR10A-10P-12S, Hirose)

Unit : mm



T17x5DA-R11

17x Applicable camera (model) 1 2/3 1/2 1/3 1/4

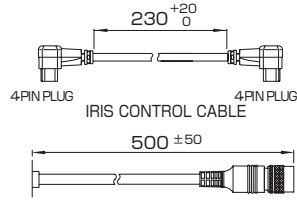

CONTROL CABLE (CONNECTOR: HR10A-10P-12S, Hirose)

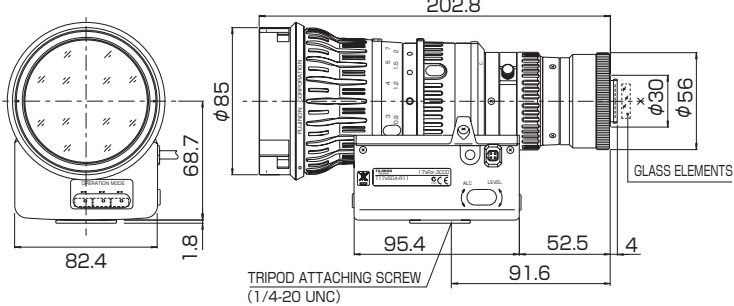

Unit : mm



		S17x6.6DA-R11	T17x5DA-R11
Focal Length (mm)		6.6 - 114 (17x)	5 - 85 (17x)
Iris Range		F1.5 - F16	F1.4 - F16
Operation	Zoom	Servo Control	
	Focus	Servo Control	
	Iris	Auto (Video Type) or Servo Control	
Angle of View(H x V)	1/2"	WIDE 51° 70' x 40° 00'	51° 30' x 39° 60'
		TELE 3° 30' x 2° 50'	3° 20' x 2° 40'
Focus Range (From the Lens Front) (m)		∞ - 0.9	
Object Dimensions at M.O.D.(H x V) (mm)	1/2"	WIDE 808 x 606	800 x 600
		TELE 48 x 36	47 x 35
Back Focal Distance (in air) (mm)		14.82	14.83
Exit Pupil Position (From Image Plane) (mm)		154	64.8
Filter Thread (mm)		M82 x 0.75	
Mass (kg)		1.45	1.4
Wiring Diagram		See P. 22	See P. 22
Remarks		Zoom/Focus/Iris can be operated manually.	

Fixed Focal

YF2.8A-SA2B

Applicable camera (model) 1 2/3 1/2 1/3 1/4

YF4A-SA2B

YF8A-SA2B

YF16A-SA2B

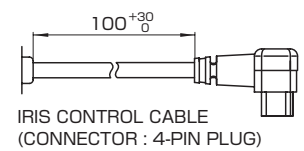
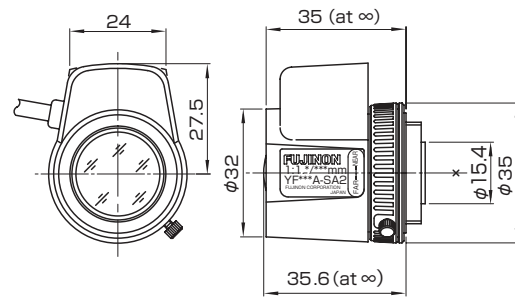

IRIS CONTROL CABLE (CONNECTOR: 4-PIN PLUG)

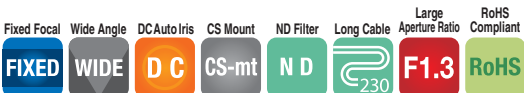

		YF2.8A-SA2B	YF4A-SA2B	YF8A-SA2B	YF16A-SA2B
Focal Length		2.8	4	8	16
Iris Range		F1.3 - T360 (Equivalent to F360)	F1.2 - T360 (Equivalent to F360)	F1.2 - T360 (Equivalent to F360)	F1.4
Operation	Focus	Manual			
	Iris	Auto (DC type)*1			
Angle of View(H x V)	1/3"	96° 15' x 71° 51'	65° 21' x 49° 27'	33° 24' x 25° 22'	17° 04' x 12° 50'
	1/4"	71° 51' x 53° 45'	49° 27' x 37° 15'	25° 22' x 19° 09'	12° 50' x 9° 39'
Focus Range (From the Lens Front) (m)		∞ - 0.1			
Mass (g)		50	40	35	35

* 1: The iris automatically closes when the camera is turned off.

* Each of the above products is also available in manual type. * Each of the above products is also available in long cable type (230 mm).

For detailed specifications, see the following website: http://www.fujifilm.com/products/optical_devices/cctv/security/

Zoom Lens Wiring

D60x16.7SR4DE-V21 P12

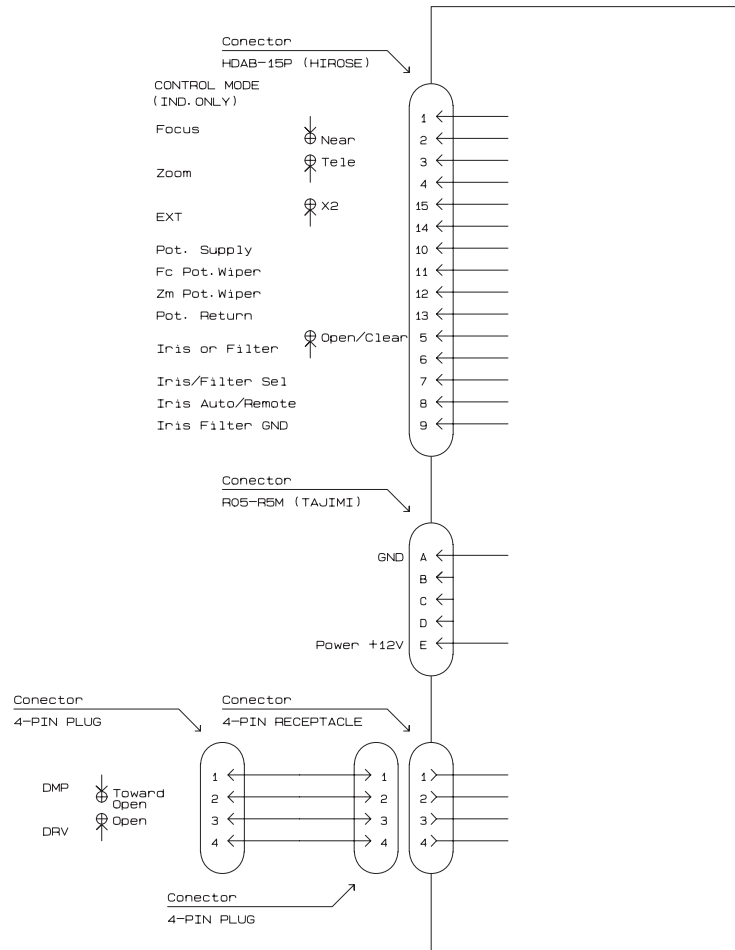

D32x10HR4D-V41 P13 D32x15.6HR4D-V41 P13

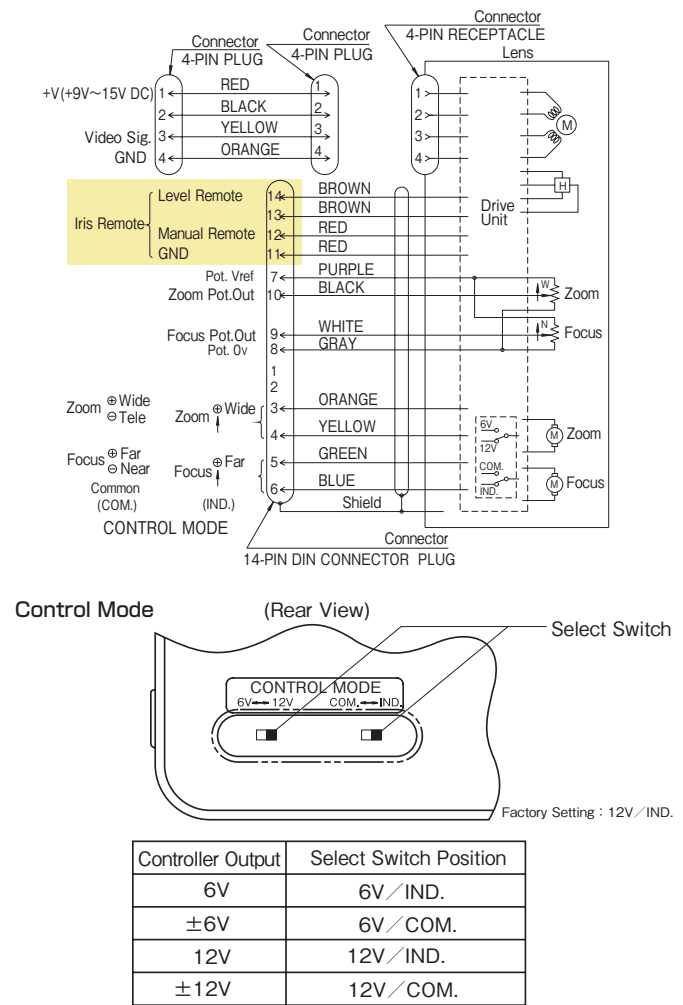

D32x10HR4D-YE1 P13 D32x15.6HR4D-YE1 P13

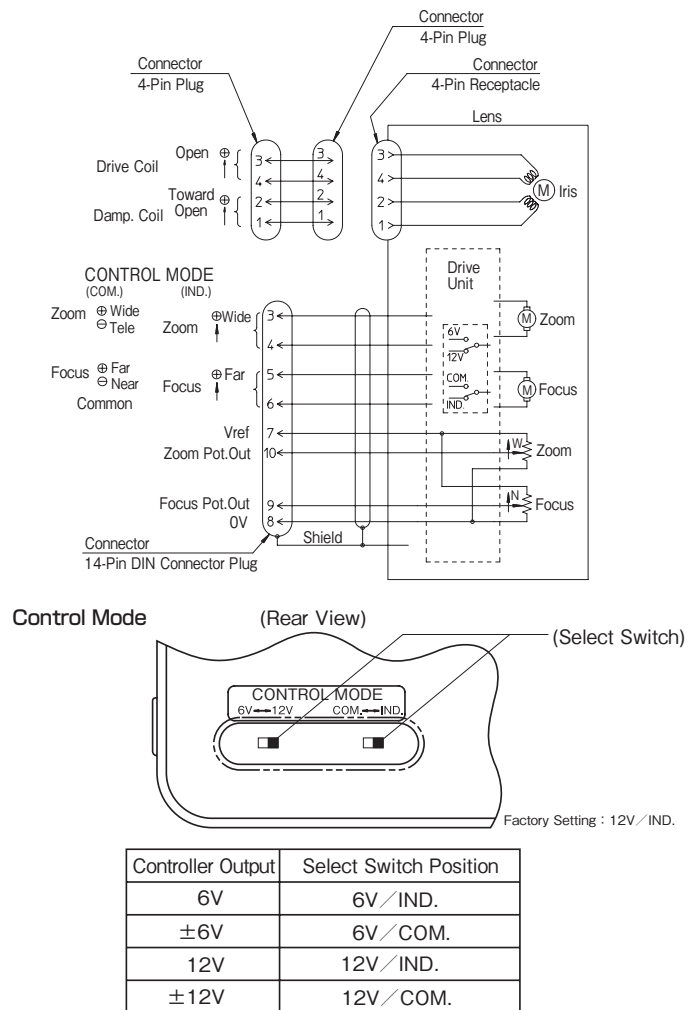

D8x7.8HA-SE2 P14 Y12x6A-SE2 P17 D12x8A-SE2 P17

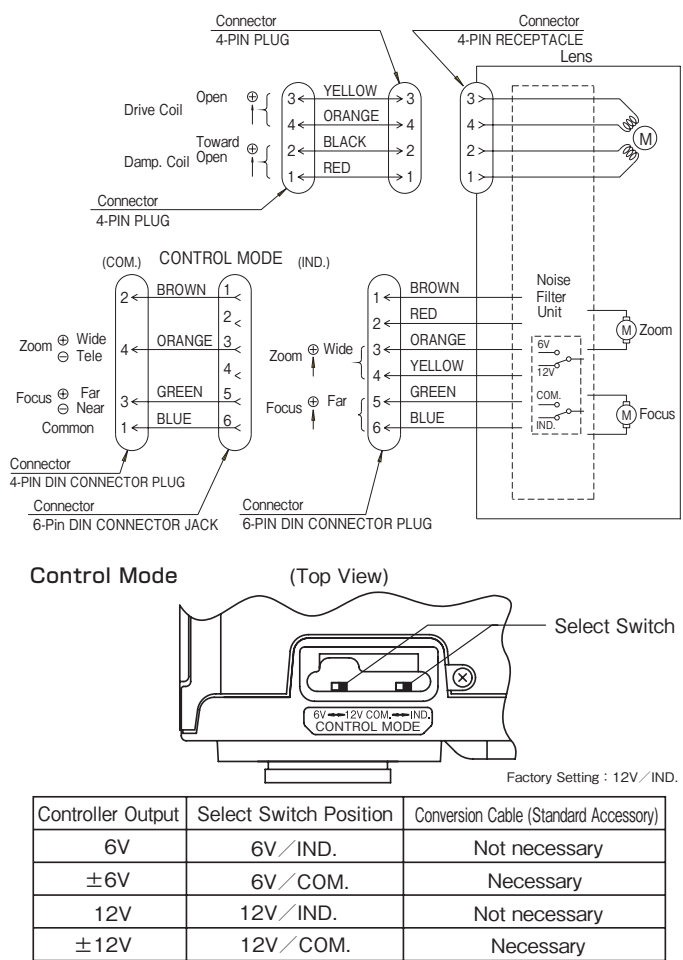

- **D8x7.8HA-YE2**..... **P14**
- **Y12x6A-YE2**..... **P17**
- **D12x8A-YE2**..... **P17**

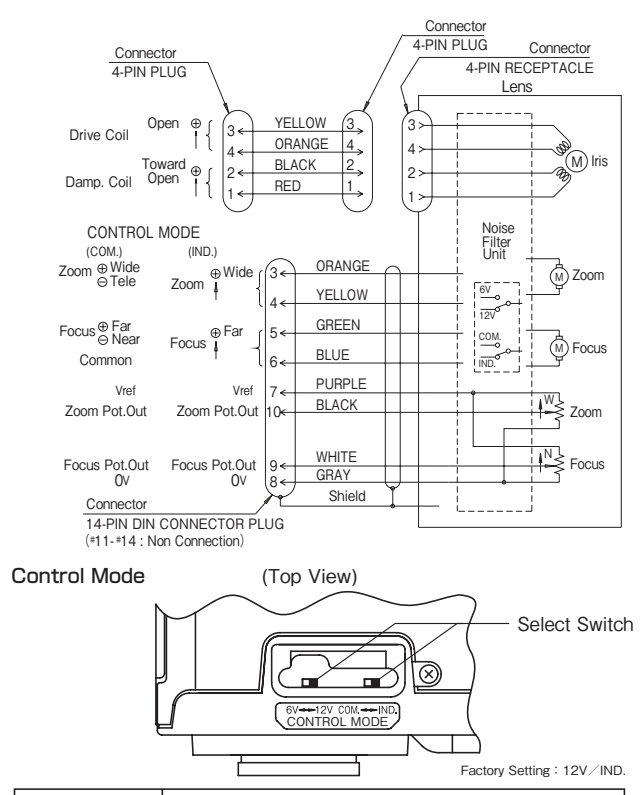

Controller Output	Select Switch Position
6V	6V / IND.
±6V	6V / COM.
12V	12V / IND.
±12V	12V / COM.

- **D8x7.8HA-V42**..... **P14**

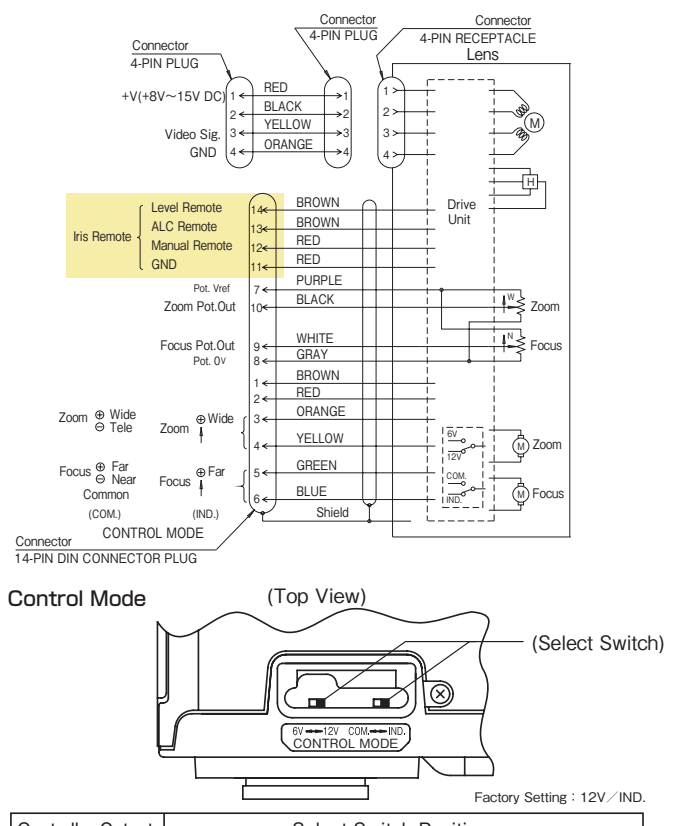

Controller Output	Select Switch Position
6V	6V / IND.
±6V	6V / COM.
12V	12V / IND.
±12V	12V / COM.

- **D60x12.5BE-V41**..... **P14**

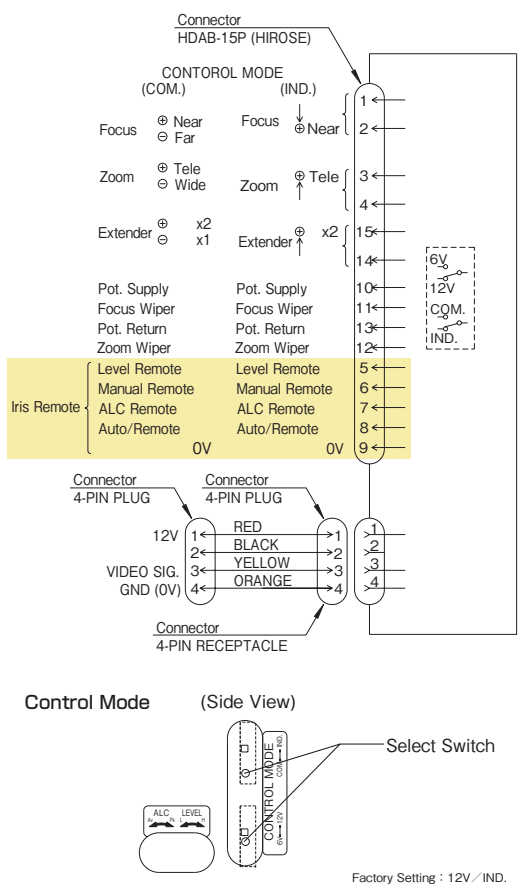

Controller Output	Select Switch Position
6V	6V / IND.
±6V	6V / COM.
12V	12V / IND.
±12V	12V / COM.

- **D60x12.5R3DE-V41**..... **P14**

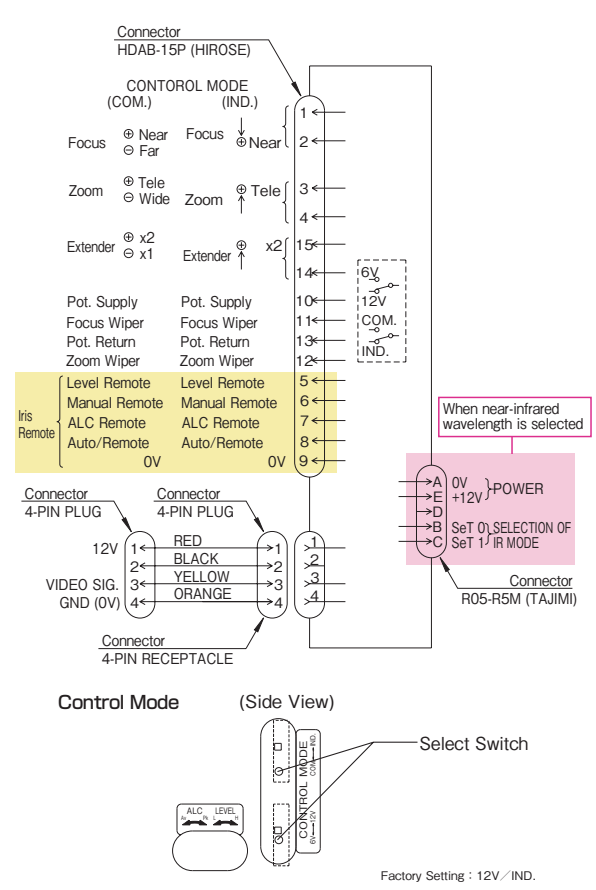

Controller Output	Select Switch Position
6V	6V / IND.
±6V	6V / COM.
12V	12V / IND.
±12V	12V / COM.

D60x12.5R3DE-ZP1 **P14**

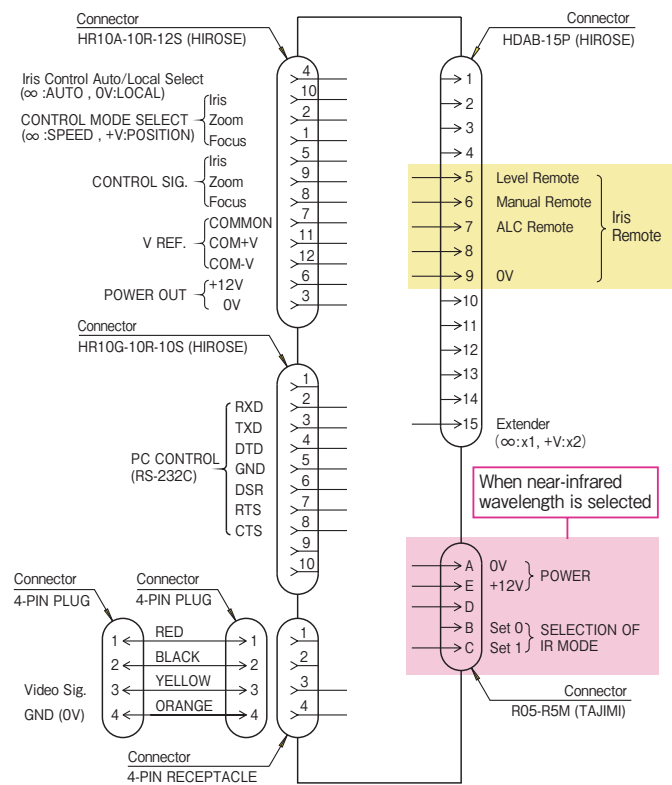

H22x11.5R2D-V41 **P16**
C22x17R2D-V41 **P16**
C22x23R2D-V41 **P15**

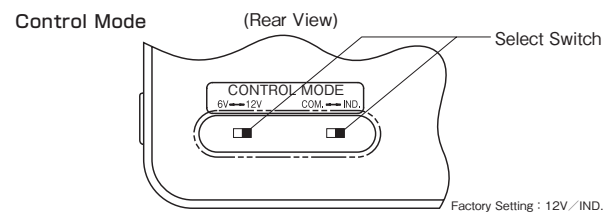
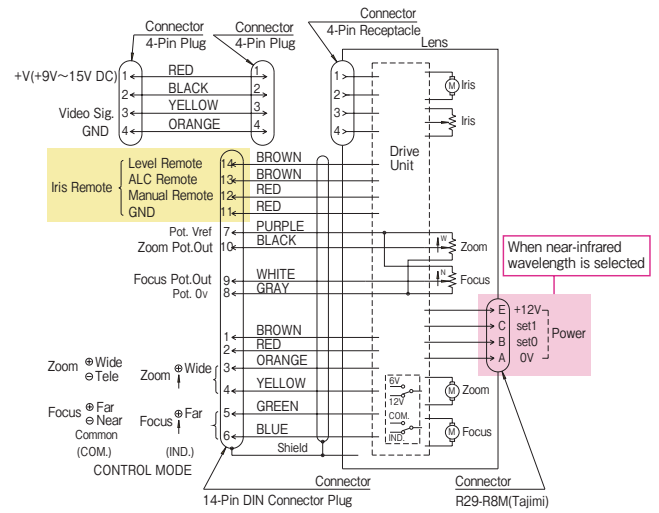

Controller Output	Select Switch Position
6V	6V / IND.
±6V	6V / COM.
12V	12V / IND.
±12V	12V / COM.

H22x11.5R2D-ZP1 **P16**
C22x23R2D-ZP1 **P15**

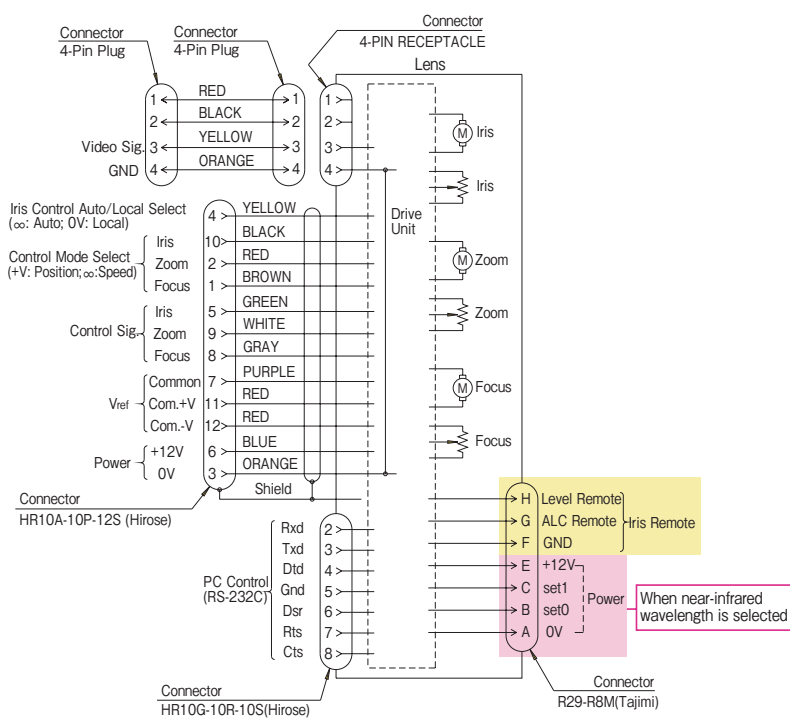

H22x11.5A-M41 **P16**
C22x17A-M41 **P16**
C22x23A-M41 **P15**

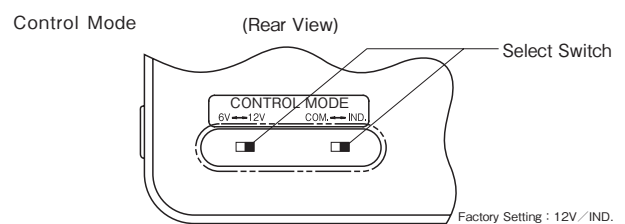
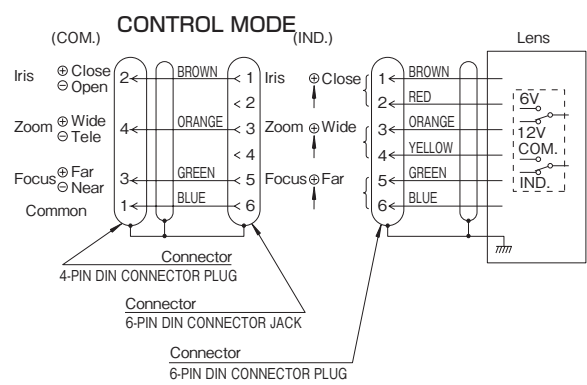

Controller Output	Select Switch Position	Conversion Cable (Standard Accessory)
6V	6V / IND.	Not necessary
±6V	6V / COM.	Necessary
12V	12V / IND.	Not necessary
±12V	12V / COM.	Necessary

C22x23B-V41 **P15**

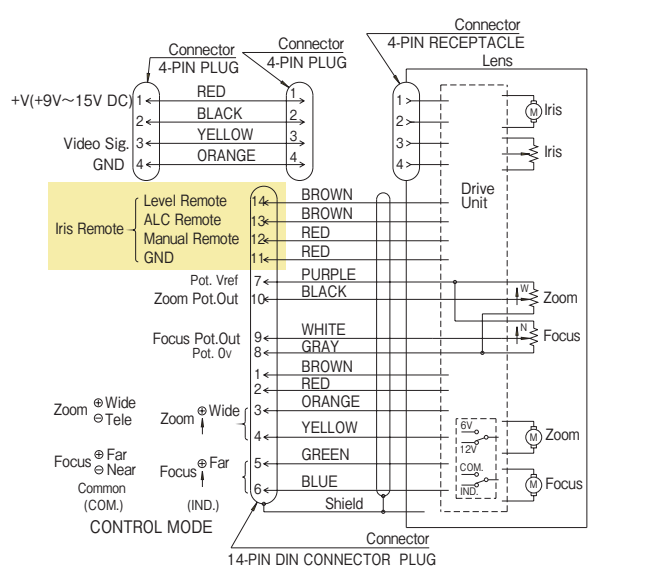

Controller Output	Select Switch Position
6V	6V / IND.
±6V	6V / COM.
12V	12V / IND.
±12V	12V / COM.

S17x6.6DA-R11 **P18**
T17x5DA-R11 **P18**

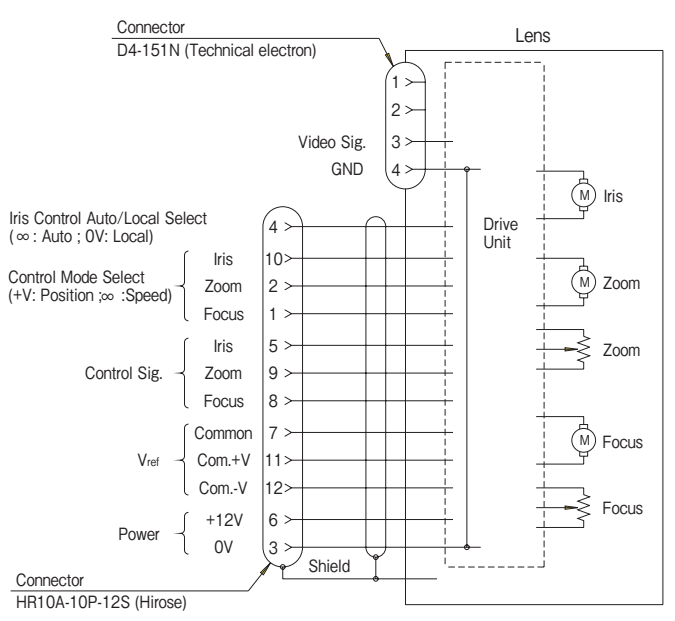

D22x9.1B-S41 **P17**
H22x11.5B-S41 **P16**
C22x17B-S41 **P16**

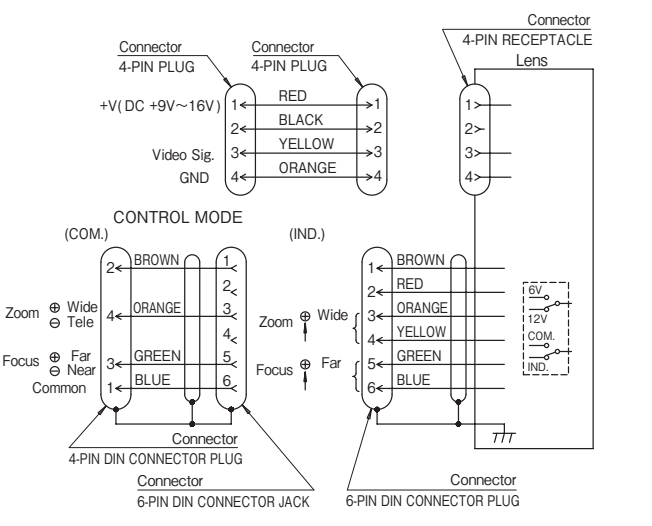

Controller Output	Select Switch Position	Conversion Cable (Standard Accessory)
6V	6V / IND.	Not necessary
±6V	6V / COM.	Necessary
12V	12V / IND.	Not necessary
±12V	12V / COM.	Necessary

D22x9.1B-Y41 **P17**
H22x11.5B-Y41 **P16**
C22x17B-Y41 **P16**

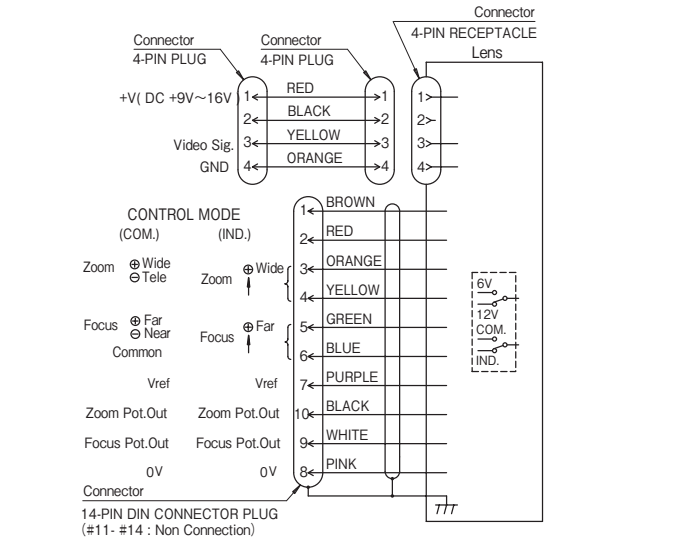

Controller Output	Select Switch Position
6V	6V / IND.
±6V	6V / COM.
12V	12V / IND.
±12V	12V / COM.

Technical Information Recommended Lens Control Circuit

Operation System - M Type Zoom Lens [Independent Mode]

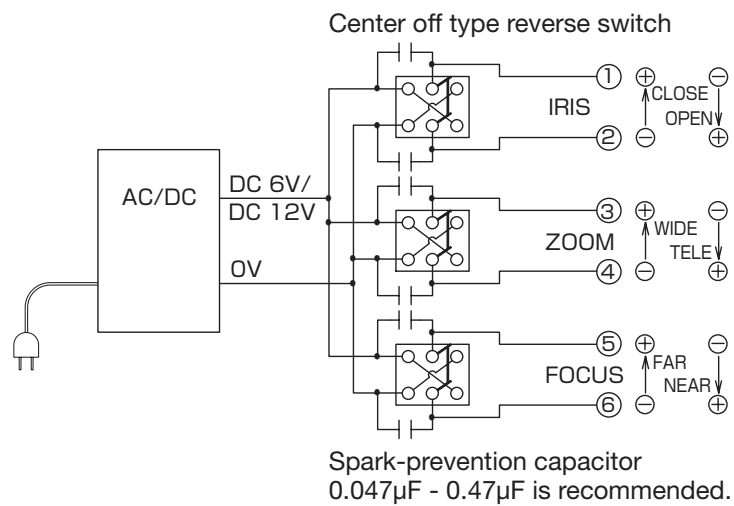

Operation System - M Type Zoom Lens [Common Mode]

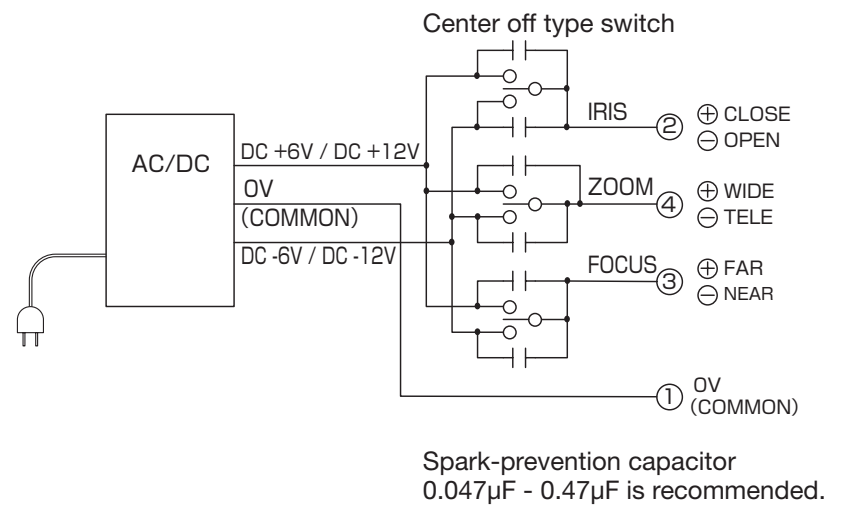

Operation System - R Type Zoom Lens

* In case of long distance (5 m or more), use a buffer amp if necessary.

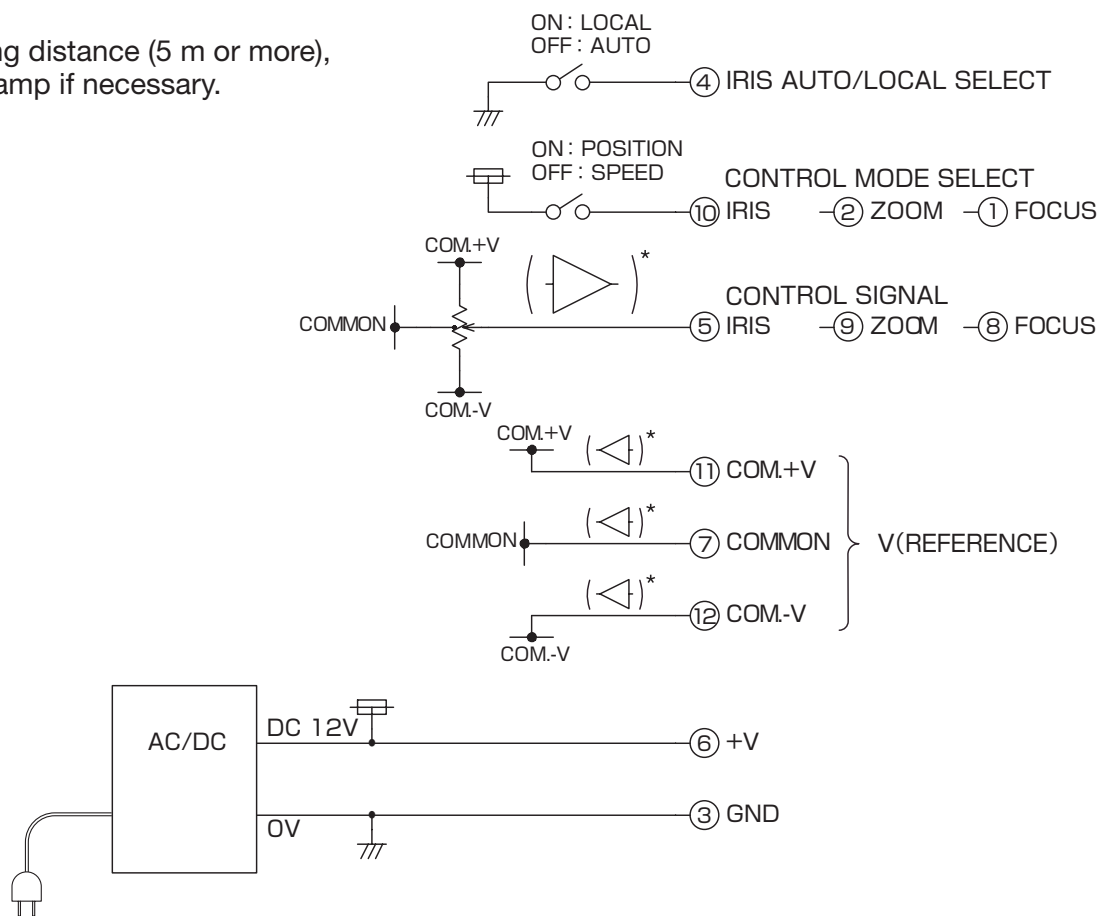

• "Independent mode" and "Common mode" can be selected with the control switch on the lenses.

Operation System - Iris Remote

Manual Remote

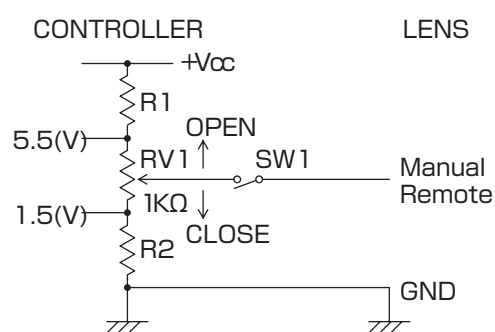

Level Remote

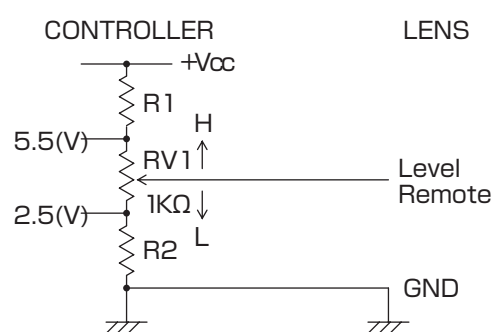

ALC Remote

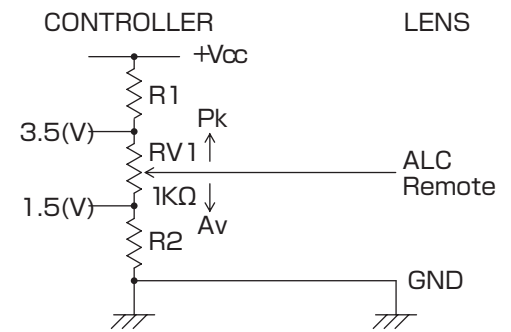

Technical Information Terminology

Model Explanation

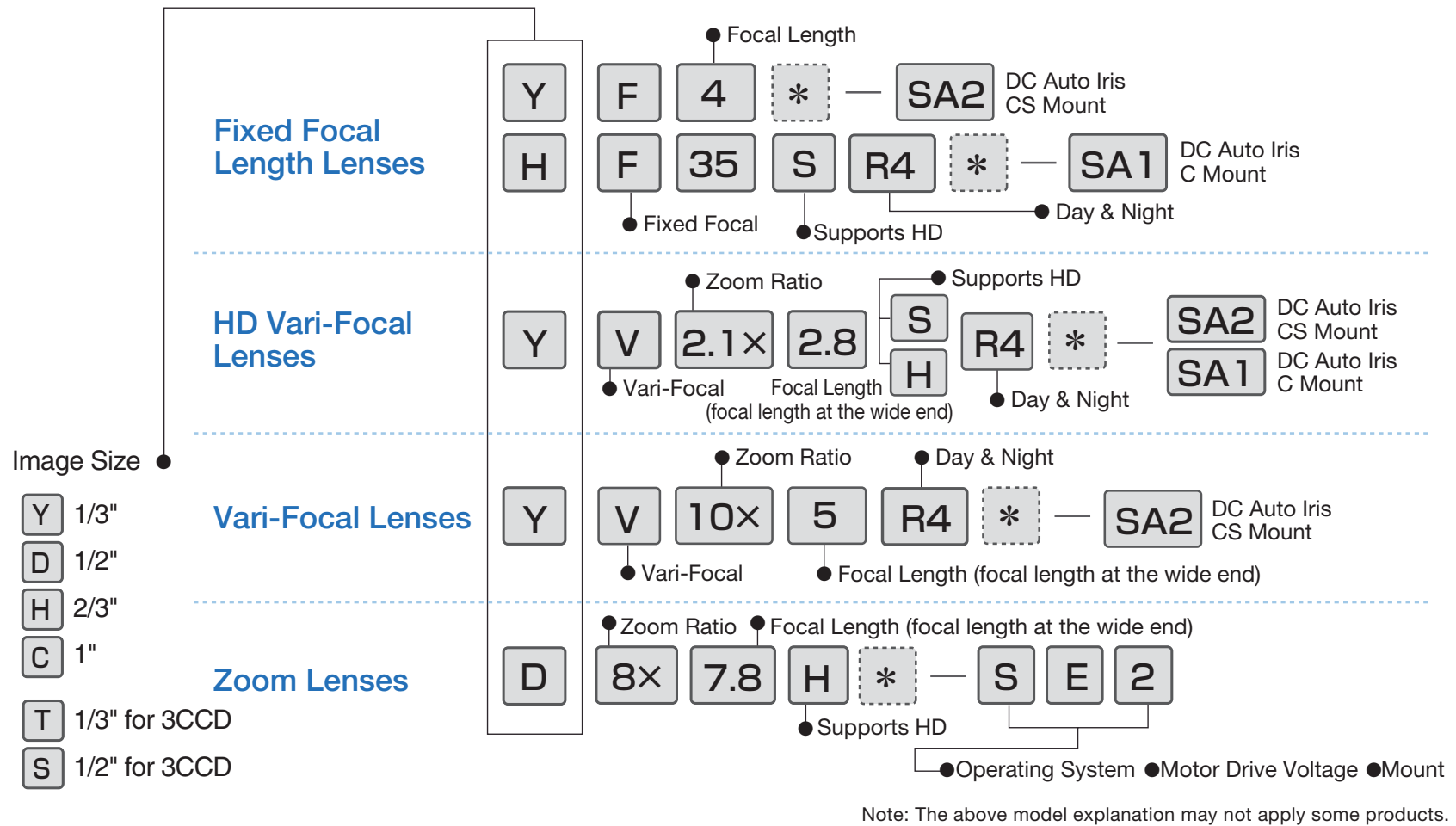
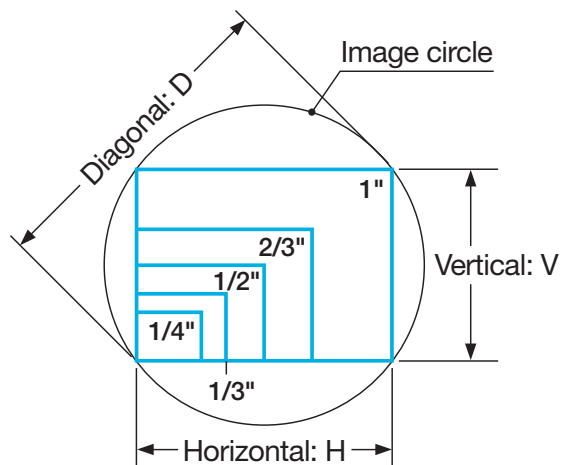

Image Sizes



- There are several types of imaging sensors for CCTV cameras, with different image sizes. The aspect ratio of a CCTV camera is normally 4:3 (H:V).

Product symbol	Image sensor	Image size (mm)		
		Horizontal: H	Vertical: V	Diagonal: D
C	1"	12.8	9.6	16.0
H	2/3"	8.8	6.6	11.0
D, S	1/2"	6.4	4.8	8.0
Y, T	1/3"	4.8	3.6	6.0
Q	1/4"	3.6	2.7	4.5
35 mm camera lens (Reference)	35 mm film	36.0	24.0	43.3

C/CS-Mount

- CCTV cameras have either a C-mount or CS-mount.

Standard	C-mount		CS-mount	
	Flange back focal length (mm)	17.526*1		12.5*1
Diameter of screw thread (mm)	1-32UNF			
Interchangeability	C-mount camera		CS-mount camera	
	C-mount lens	○	CS-mount lens	○*2
	CS-mount lens	×		○

*1 Length in air

*2 Will need a C-mount adapter ring (5 mm) when fitting a C-mount lens to a CS-mount camera.

Focal Length

- The focal length will be the distance from the back principal point to the image plane. Lower the focal length wider the image.

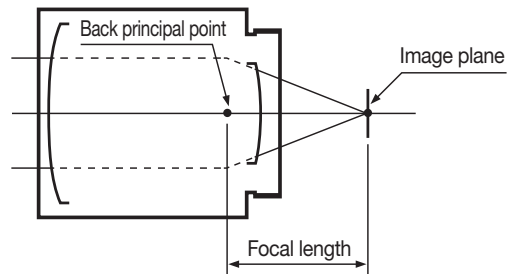

Flange Back and Back Focal Distance

- Flange back will be the distance between the mechanical mount surface and image plane. Back focal distance will be the distance between the rear end of the lens part and the image plane.

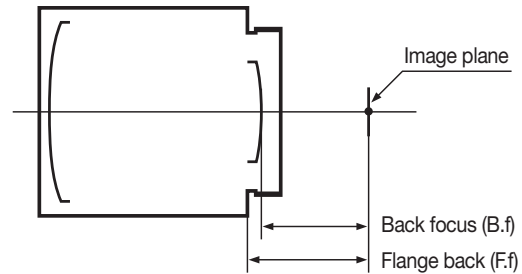

Angle of View

- The angle of view is the object size that can be captured at a specified image size, which is represented by angular measure. Normally the angle of view is measured assuming a lens is focused at infinity. When using a lens of the same focal length with a different image size, the angle of view will differ.

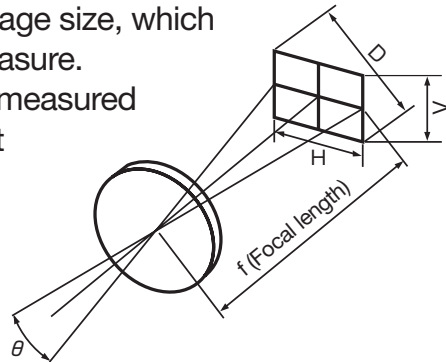

$$\theta = 2 \tan^{-1} \frac{Y'}{2f}$$

θ : Angle of view
 Y' : Image size
 f : Focal length

Example

The angle of view when the camera size is 1/2" and the focal length is 12.5 mm:

$Y' : 6.4$
 $f : 12.5$

$$\theta = 2 \tan^{-1} \frac{6.4}{2 \times 12.5} = 28.72^\circ$$

Brightness of a Lens (F and T No.)

- The F No. is an indication of the brightness of lens. The smaller the value, the brighter the image produced by the lens. The F No. is inversely proportional to the effective diameter of the lens and directly proportional to the focal length. The scale on the iris ring of lens uses a ratio of 2, because the value of light incident on a lens is proportional to the cross section of luminous flux (square of diameter). In other words, the brightness decreases by half each time the F No. is increased by one F stop.
- The F No. is a value determined on the assumption that the transmittance of the lens is 100%. Virtually all lenses however, have different spectral transmittance, and thus, the same F No. can have different levels of brightness. To eliminate this inconvenience, a system has been developed to consider both F No. and spectral transmittance, the T No. The T No. and the F No. are related to each other as shown in right:

$$F \text{ No.} = \frac{f}{d}$$

f : Focal length of a lens
 d : Effective diameter of a lens

$$T \text{ No.} = \frac{F \text{ No.}}{\sqrt{\text{Transmittance (\%)}}} \times 10$$

Exit Pupil Position

- The exit pupil is the image (virtual image) reflected by the lens located at the back of the lens diaphragm. The exit pupil position is generally represented with the distance between the image plane and the exit pupil. "-" (minus)" indicates closer to the object, and "+" (plus)" toward the camera.

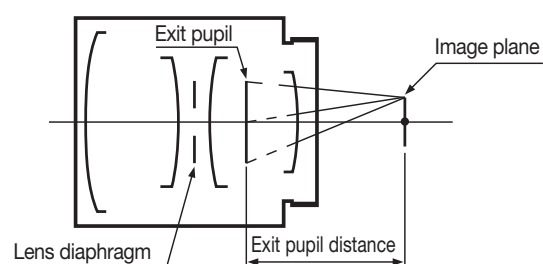

M.O.D.

- The M.O.D. (minimum object distance) is the closest distance to the object at which an image can be taken. This is the distance from the vertex of the front lens.

Field of View and Focal Length

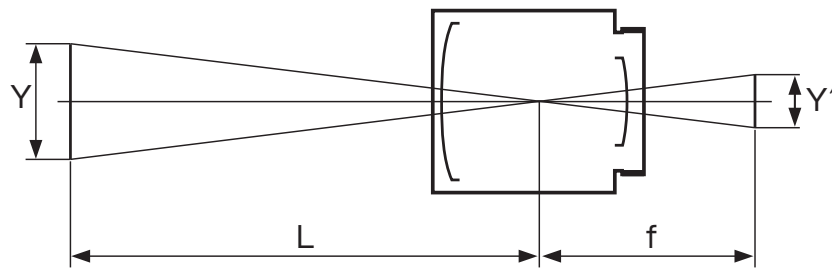

Y : Object size
 Y' : Image size
 L : Object distance
 f : Focal length

(1) How to calculate the field of view

If the distance to the object is finite, you can use the following formula to calculate the field of view.

$$Y = Y' \cdot \frac{L}{f}$$

Example

A 1/3" CCD camera with an 8 mm lens is used, and the distance to the object is 3 m. The maximum horizontal width as viewed on the monitor can be calculated as follows.

Y' : 4.8
 L : 3000
 f : 8

$$Y = 4.8 \times \frac{3000}{8} = 1800 \rightarrow \text{Horizontal width 1.8 m}$$

(2) How to calculate focal length

If the distance to the object is finite, you can use the following formula to calculate the focal length.

$$f = Y' \cdot \frac{L}{Y}$$

Example

A 1/3" CCD camera is used, and the distance to the object is 3 m and the horizontal width of the object is 2 m. The focal length to capture the complete object size can be calculated as follows.

Y' : 4.8
 L : 3000
 Y : 2000

$$f = 4.8 \times \frac{3000}{2000} = 7.2 \rightarrow \text{Focal length approx. 7 mm}$$

Depth of Field

- When focusing on a certain area in front of and behind the deep object appears in focus. This area is called the depth of field. This is because the focus appears sharp if the focus misalignment is under a certain volume. This certain volume is called the permissible circle of confusion.

The depth of field has following properties.

- The larger the F No. is, the wider the depth of field becomes.
- The shorter the focal length is, the wider the depth of field becomes.
- The longer the distance to the object is, the wider the depth of field becomes.
- The backward depth of field is wider than the forward depth of field.

Image sensor	Permissible circle of confusion
1"	0.03 mm
2/3"	0.021 mm
1/2"	0.015 mm
1/3"	0.011 mm
1/4"	0.008 mm

The depth of field can be calculated by the following formula.

Backward depth of field $T_r = \frac{\delta \cdot F \cdot L^2}{f^2 - \delta \cdot F \cdot L}$

Forward depth of field $T_f = \frac{\delta \cdot F \cdot L^2}{f^2 + \delta \cdot F \cdot L}$

Depth of field = $T_r + T_f$

Focal depth = $2\delta \cdot F$

f: Focal distance
 F: F No.
 δ : Permissible circle diameter of confusion
 L: Object distance

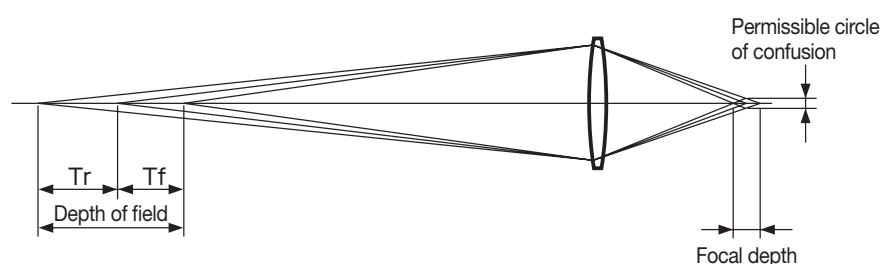

Distortion

● Distortion is an aberration where the geometric figure of the object is not reproduced faithfully at the image plane. It is normally represented by the level shift of an image point from its ideal position by a percentage of image height or width.

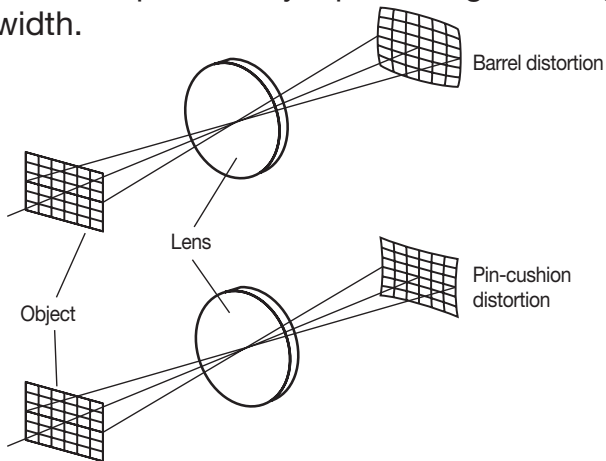

MTF (Modulation Transfer Function)

● MTF (Modulation Transfer Function) represents the declining contrast rate when shooting a chart consisted of black and white lines.

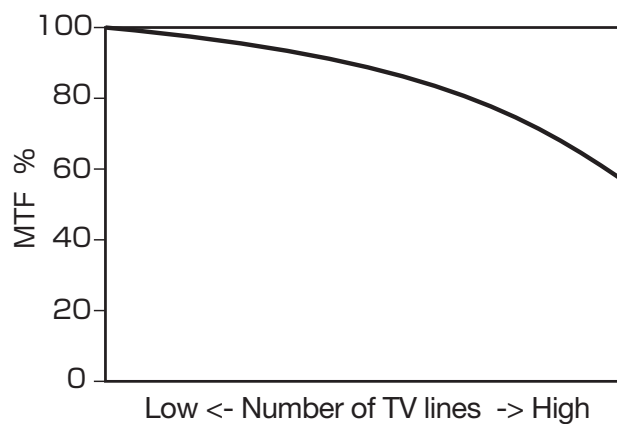

HD Lens

● Based on design techniques accumulated through our experience in production of broadcast lenses, high resolution, small and light-weight HD lenses with minimal aberrations have been realized.

The chart at the right shows the difference between an HD lens and a conventional CCTV lens. As the number of TV lines increases, the disparity in MTF becomes greater.

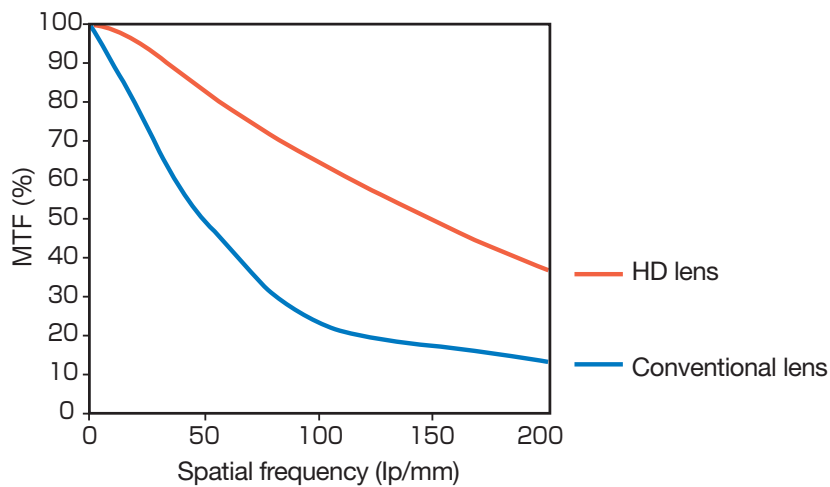

3CCD Camera Lens

● 3CCD cameras have thicker glass between the lens and the CCD than that of single CCD cameras because they have three CCDs to correspond with the red, blue and green colors separated by the prism. Fujifilm's 3CCD lenses are designed to optimally match 3CCD cameras. The chart shown at the right explains the difference in MTF when a 3CCD lens or a single CCD lens is mounted on a 3CCD camera.

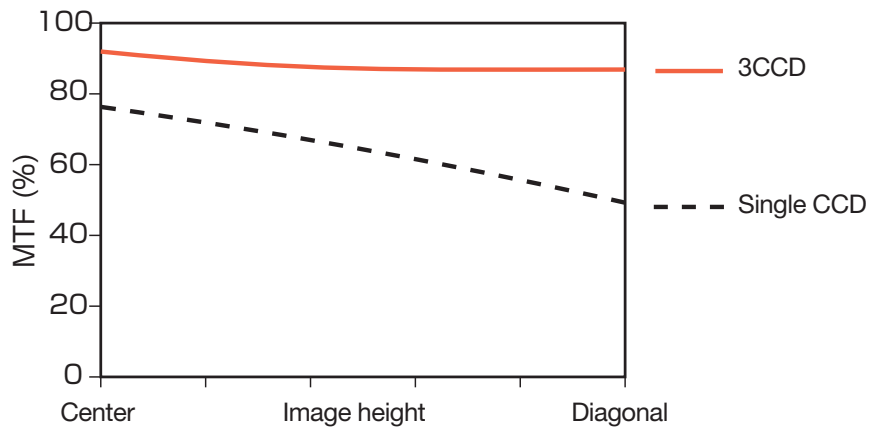

Day & Night Lens

● The day & night lens uses an advanced optical design, special optical glass, and other state-of-the-art technologies to focus light (visible to near-infrared 400- 1000 nm) on the same plane to prevent the focus to become blurry enabling sharp images.

■ A standard lens (for visible light) is mounted on a day & night camera, and used under near-infrared light.

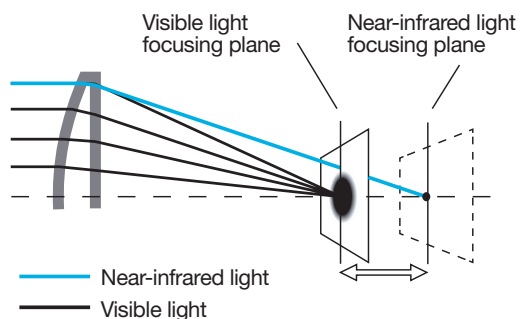

Result: Blurry image

■ A day & night lens is mounted on a day & night camera, and used under near-infrared light.

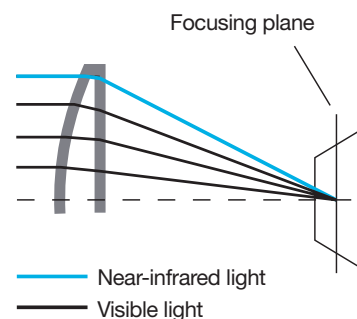

Result: Clear image without getting blurry

FUJIFILM

Japan / North East Asia

FUJIFILM Corporation

Optical Device Business Div.

1-324 Uetake, Kita-ku, Saitama City Saitama, 331-9624, Japan

TEL: +81 (0)48-668-2152 FAX: +81 (0)48-651-8517

<http://www.fujifilm.co.jp/>

North & Latin America

FUJIFILM North America Corporation

Optical Devices Div.

10 High Point Dr. Wayne, NJ 07470-7434, U.S.A.

TEL: +1-973-633-5600 FAX: +1-973-633-5216

<http://www.fujinon.com/>

Hong Kong / Taiwan

FUJIFILM Hong Kong Limited

Optical Devices Business Division

Suites 2512-14, 25/F., Tower 6, The Gateway, Harbour City,

9 Canton Road, Tsimshatsui, Kowloon, Hong Kong

TEL: +852-2311-1228 FAX: +852-2724-1118

<http://www.fujinon.com.cn>

Southeast Asia & West Asia

FUJIFILM Regional Services (Singapore) Pte Ltd.

10 New Industrial Road, Fujifilm Building Singapore 536201

TEL: +65 (0)63839933 FAX: +65 (0)63835666

<http://www.fujinon.com.sg/>

Oceania

FUJIFILM Australia Pty Ltd.

114 Old Pittwater Road, Brookvale, N.S.W. 2100, Australia

TEL: +61 (0)2-9466-2600 FAX: +61 (0)2-9905-3801

<http://www.fujifilm.com.au/>

Europe / Middle East / Africa

FUJINON (EUROPE) GmbH

Halskestrasse 4, 47877 Willich, Germany

TEL: +49-2154-924-132 FAX: +49-2154-924-290

<http://www.fujinon.de/>

E-mail: Fujinon@fujinon.de

FUJIFILM France S.A.S.

Etablissement de Montigny 43, avenue des 3 peuples

MONTIGNY-LE-BRETONNEUX 78185 ST-QUENTIN-EN-YVELINES CEDEX

TEL: +33-1-3930-1616 FAX: +33-1-3930-0248

<http://www.fujifilm.fr/>

E-mail: Fujinon@fujinon.de

FUJINON (EUROPE) GmbH Russian Branch

1st Magistralnyi tupik 5A Business Centre "Magistral Plaza" 4th floor c/o CJSC

(ZAO) Fujifilm-Ru 123290, Moscow, Russian Federation

TEL: +7-495-797-3512 FAX: +7-495-797-3513

<http://www.fujinon.ru>

E-mail: Fujinon@fujinon.de

FUJINON (EUROPE) GmbH Dubai Branch

P.O. BOX 18408 LOB 16, Room 419 Jubel Ali, Dubai, U.A.E.

TEL: +971-4-8873074 FAX: +971-4-8873053

E-mail: fujinonm@emirates.net.ae

China

FUJIFILM (China) Investment Co., Ltd.

Optical Device Headquarter Beijing Office

Unit 1109, Beijing East Ocean Center 24A Jianguomenwai Avenue, Beijing,

China 100004

TEL: +86 (0)1-6515-5741 FAX: +86 (0)1-6515-5743

Authorized Fujifilm Service Agent.

Due to a continuous process of product improvement, design and specifications are subject to change without notice.



For your safety

Be certain to read the instructions for use before using any equipment.

Printed in Japan FPT2011 04. FGKE-001-00