

FCB-EH6300

High Definition Colour
Camera Block

Preliminary brochure



IMAGE SENSING SOLUTIONS

Sony, a leader in high-definition (HD) technology and the imaging industry, is combining its strengths with the introduction of its new compact FCB-EH6300 20x HD Colour Block Camera.



FCB-EH6300

Features

- **Excellent 1080p (1920 x 1080) HD picture quality**
- **The “Exmor™” CMOS sensor realizes high image quality and high sensitivity**
 - High Sensitivity mode – 0.5 lx (F1.6, 50IRE, Color)
 - Normal mode – 1.7 lx (F1.6, 50IRE, Color)
- **Powerful zoom capability**
20x optical and total 240x with 12x digital zoom
- **Various signal systems and output modes**
 - **HD**
 - Signal system – 1080p/29.97, 1080p/25, 1080i/59.94 (Frame out: 29.97 PsF), 1080i/50 (Frame out: 25 PsF), 720p/59.94, 720p/50, 720p/29.97, 720p/25
 - Video output – Analog: Component (Y/Pb/Pr), Digital: Y/Cb/Cr 4:2:2 via LVDS (Y: 8-bit, C: 8-bit)
 - **SD**
 - Signal system – NTSC, PAL
 - Video output – VBS
- **Simple connection - one cable, one connector**
 - Covering video, VISCA communication, and power supply with a single cable
 - Supports both 30-pin thin coaxial (digital and analog output) and 24-pin FFC interfaces (analog output only)
- **Security-oriented functions include:**
 - Wide-D technology (On, Off, Auto, and Ratio Fix)
 - Day/Night function (On, Off, Auto, Threshold Enabled)
 - Digital noise reduction (Up to 5 levels)
 - Spherical Zone Masking (24 Zones with various PTZ controls)
 - Motion Detection Alarm (4 Zones with several triggering and threshold modes)
 - Sodium Vapor Lamp Fix/Auto, One-push, Manu

Featuring full 1920 x 1080 HD resolution, wide-dynamic range, and auto ICR functions, this amazing FCB HD camera is ideal for security, intelligent traffic, unmanned aerial vehicles, video conferencing and low-vision applications.

Incorporating a 1/3-type “Exmor™” CMOS sensor, the FCB-EH6300 camera boasts approximately 2 Megapixels for exceptional HD picture quality with high sensitivity. In addition, the FCB-EH6300 inherits a multitude of features from Sony’s world-renowned FCB Series such as Spherical Privacy Zone Masking, E-Flip and various picture effects.

Exmor™

Other Features

Other Features

- Various modes for White Balance (Auto, ATW, Indoor, Outdoor, Outdoor Auto, Sodium Vapor Lamp Fix/Auto, One-push, Manual)
- Picture effects (E-Flip, Nega Art, Black & White, Mirror Image, Colour Enhancement)
- Picture freeze
- Temperature readout
- Slow AE response (Approx. 5 min.)
- Title display (20 characters per line, max. 11 lines)
- Camera mode display (English)
- Electronic shutter/slow shutter
- Spot AE
- High Resolution Mode
- IR Focus Correction Function
- 4 Presets for Gamma Control
- 4 Levels of Chrominance Suppression
- Colour reproduction adjustment

Specifications

FCB-EH6300	
Image sensor	1/3-type "Exmor" CMOS
Effective number of pixels	Approx. 2 Mega pixels
Lens	20x optical zoom
	f=4.7 mm (wide) to 94.0 mm (tele)
Digital zoom	12x (240x with optical zoom)
Angle of view (H)	1080p/30 mode: 55.4° (wide end) to 2.9° (tele end) 720p/60, 30 mode: 37.6° (wide end) to 1.95° (tele end)
Minimum working distance	10 mm (wide) to 800 mm (tele)
Sync system	Internal
Minimum illumination	High sensitivity mode: 0.5 lx (F1.6, 50 IRE, ICR Off), 0.095 lx (F1.6, 50 IRE, ICR On)
	Normal mode:
Recommended illumination	100 to 100,000 lux
S/N ratio	More than 50 dB
Signal system	HD 1080p/29.97, 1080p/25, 1080i/59.94 (Frame out: 29.97 PsF), 1080i/50 (Frame out: 25PsF), 720p/59.94, 720p/50, 720p/29.97, 720p/25
	SD NTSC, PAL
Video output	HD Analog: Component (Y/Pb/Pr) Digital: Y/Cb/Cr 4:2:2 via LVDS (Y: 8 bit, C: 8 bit)
	SD VBS: 1.0 Vp-p (sync negative) VISCA (TTL signal level) Baud rate: 9.6 Kb/s, 19.2 Kb/s, 38.4 Kb/s Stop bit: 1/2 bit selectable
Camera control interface	Electronic shutter 1/1 to 1/10,000 s, Total 22 steps
White balance	Auto, ATW, Indoor, Outdoor, Outdoor Auto, Sodium Vapor Lamp Fix/Auto, One-push, Manual
Gain	Auto/Manual (-3 to +28 dB, +2 dB step/Total 16 steps)
AE control	Auto, Manual, Priority mode (shutter priority & iris priority), Bright, EV compensation, Slow AE
Slow AE	Approx. 5 minutes
Focusing system	Auto (Sensitivity: normal, low), One-push AF, Manual, Infinity, Interval AF, Zoom Trigger AF
Storage temperature	-20°C to +60°C (-4°F to +140°F)
Operating temperature	-5°C to +60°C (23°F to 140°F)
Storage humidity	20% to 95%
Operating humidity	20% to 80%
Power requirements	6.0 V to 12.0 V DC
Power consumption	To be confirmed
Weight	260 g (4.2 oz)
Dimensions (W x H x D)	50.0 x 60.0 x 87.9 mm (2 x 2 3/8 x 3 1/2 inches) Includes protrusions

Pin assignment & connector

CN601

30-pin Thin Coaxial Power supply/Communication/ Analog/Digital

Pin No.	Name	Level
1	TXOUT3+	
2	TXOUT3-	
3	TXCLKOUT+	
4	TXCLKOUT-	
5	TXOUT2+	
6	TXOUT2-	
7	TXOUT1+	
8	TXOUT1-	
9	TXOUT0+	
10	TXOUT0-	
11	GND	
12	TxD	CMOS 5 V (Low: MAX 0.1 V, High: min 4.4 V)
13	RxD	CMOS 5 V (Low: Max 0.8 V, High: min 2.0 V)
14	DC IN	6 to 12 V DC
15	DC IN	6 to 12 V DC
16	DC IN	6 to 12 V DC
17	DC IN	6 to 12 V DC
18	DC IN	6 to 12 V DC
19	GND	
20	GND	
21	GND	
22	GND	
23	GND	
24	GND	
25	NC	
26	RESET	
27	VBS-OUT	
28	Y	HD Analog Component
29	Pb	HD Analog Component
30	Pr	HD Analog Component

Connector: USL00-30L-C (KEL CORP.)

CN501

24-pin FFC Power supply/Communication/ Analog

Pin No.	Name	Level
1	GND	
2	TxD	CMOS 5 V (Low: MAX 0.1 V, High: min 4.4 V)
3	RxD	CMOS 5 V (Low: Max 0.8 V, High: min 2.0 V)
4	RESET	
5	GND	
6	NC	
7	GND	
8	NC	
9	GND	
10	VBS-OUT	
11	GND	
12	Y-OU	HD Analog Component
13	GND	
14	Pb-OUT	HD Analog Component
15	GND	
16	Pr-OUT	HD Analog Component
17	GND	
18	Power	6 to 12 V DC
19	Power	6 to 12 V DC
20	Power	6 to 12 V DC
21	Power	6 to 12 V DC
22	GND	
23	Power	6 to 12 V DC
24	GND	

Connector: 04 6240 224 006 848+ (KYOCERA ELCO)

Dimensions

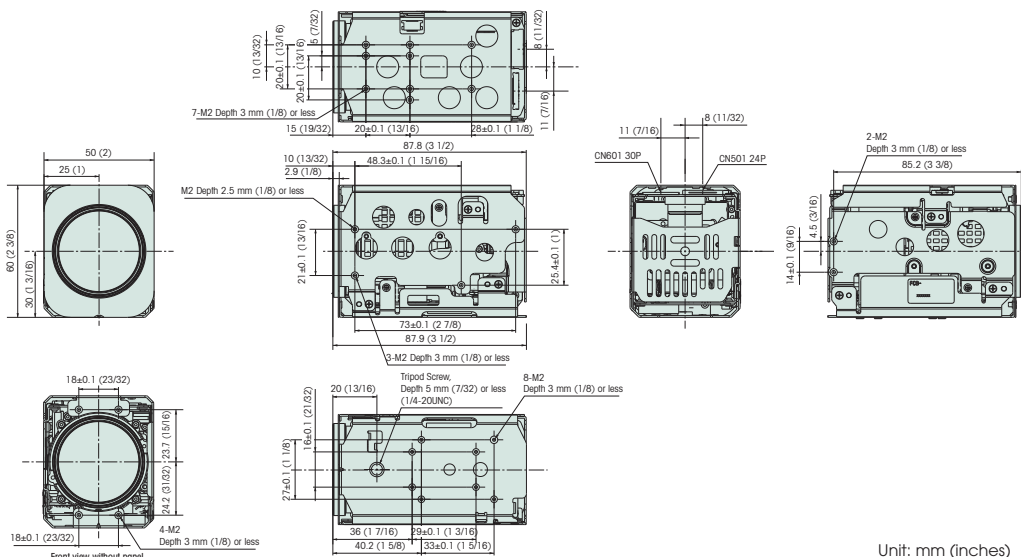

Distributed by

© 2011 Sony Corporation. All rights reserved. Reproduction in whole or in part without written permission is prohibited. Features and specifications are subject to change without notice. The values for mass and dimension are approximate. VISCA is a trademark of Sony Corporation. All other properties are the property of their respective owners. Sony is a registered trademark of Sony Corporation.

ISS 110510

SONY
make.believe