

IK-HD5

3-CMOS 1080 p/i
3G/HD-SDI & DVI-D
HD VIDEO CAMERA



Features

- 3-CMOS HD Sensors, 2.1MP, progressive, 1/2.9"
- 3G-SDI/HD-SDI and DVI-D output, 1920 x 1080
- Switchable between 1080p and 1080i
- Up to 1,000 TV lines resolution
- 5 User-configurable scene files
- Binning mode for 4x increase in sensitivity
- Image flip and mirror
- Gen-lock for 3D and multi-camera use
- Remote control via RS232
- C-mount lens mount

For enhanced near-infrared applications

- Removable optical low pass filter
- Provides switchable output between full-HD video in visible and near-infrared spectrums
- Approximately 3dB increased sensitivity in near IR
- Expanded menu functions for red filter IR mode

Toshiba introduces the latest 3-CMOS camera innovation, a progressive-scan full-HD 1080p/1080i video camera featuring 3G-SDI/HD-SDI and DVI-D outputs and removable optical low pass filter (OLPF) for dual-mode imaging applications switchable between visible light and near-infrared visualization. This HD camera can be used for any HD video application as well as applications which use fluorescing agents. The IK-HD5 imaging capabilities are well-suited as a component of surgical microscopy, endoscopy, IR inspection and defense imaging systems.

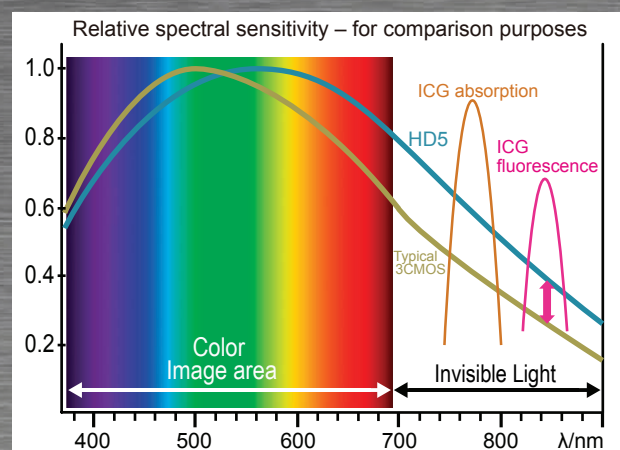

Incorporating Toshiba's innovative three-chip technology, the IK-HD5 provides approximately 3dB increased sensitivity in the near-infrared spectrum through 700-870 nm. When equipped with the appropriate optics and filters, the IK-HD5 can be used for both visible light and near IR imaging applications such as indocyanine green (ICG) and other fluorescing agents.



TOSHIBA
Leading Innovation >>>

IK-HD5

Camera Head Specifications

IK-HD5H

Image Sensor	3-CMOS, 1/2.9 inch, 2.1MP progressive
Output Resolution	Horizontal: 1920, Vertical: 1080
Resolution : H : V	1000 TV lines standard 1000 TV lines standard
Sensitivity	F10 standard (59.94 Hz setting) F11 standard (50 Hz setting) (at 2000 lx, 3000 K)
Minimum Illumination	4.8 lx (59.94 Hz setting) 4.0 lx (50 Hz setting) at F2.2, 20 dB, BINNING: ON 9.6 lx (59.94 Hz setting) 8.0 lx (50 Hz setting) at F2.2, 20 dB, BINNING: OFF
S/N Ratio	56 dB standard AGC: OFF, Gamma: OFF, Enhance: OFF
Operating Temperature	0°C to 40°C / 32°F to 104°F
Operating Humidity	Less than 90% (non-condensing)
Weight	Approx. 93 g (3.3 oz)
Dimensions	W: 32.6 mm H: 38.6 mm D: 41 mm (1.28" x 1.52" x 1.61") Protruding portion is not included

Camera Head Exterior Dimensions

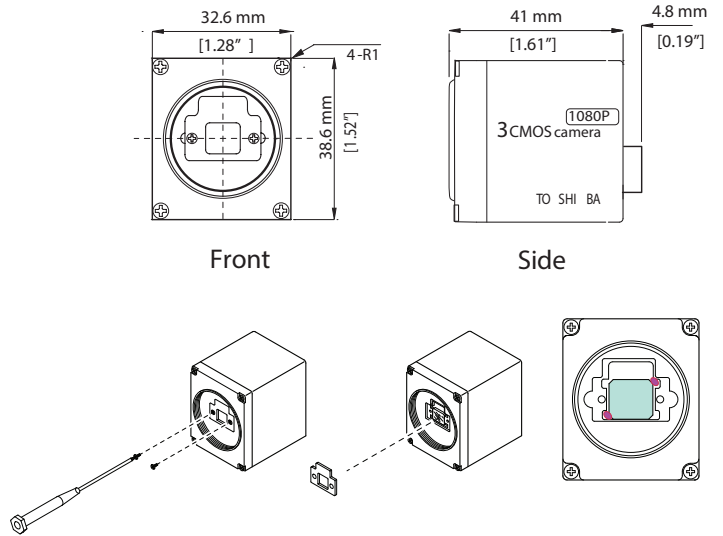

Controller Front and Back Panels

IK-HD5E FRONT

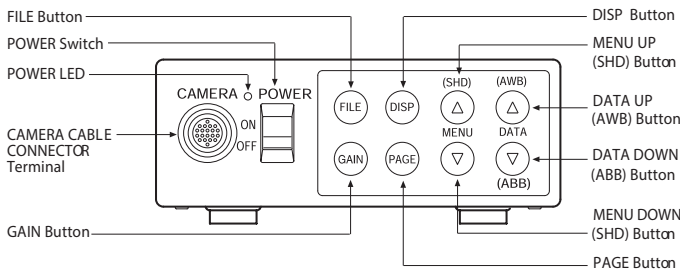

IK-HD5E REAR

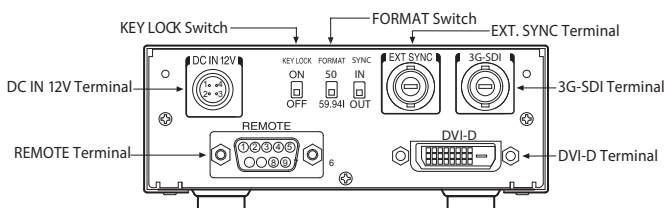

IK-HD5E Controller Specifications

Power Supply	12V DC±10%
Power Consumption	10.3 W
Scanning System	Progressive / Interlaced (Selectable)
Scan Frequency	H: 67.433 kHz, V: 59.94 Hz :1080p / 59.94 Hz H: 56.250 kHz, V: 50 Hz :1080p / 50 Hz H: 33.716 kHz, V: 59.94 Hz :1080i / 59.94 Hz H: 28.125 kHz, V: 50 Hz :1080i / 50 Hz
Operating Temperature	0°C to 40°C / 32°F to 104°F
Operating Humidity	Less than 90% (non-condensing)
Weight	Approx. 600 g (1.32 lbs.)
Dimensions	W: 110 mm, H: 40 mm, D: 186 mm (4.33" x 1.58" x 7.32")
Scene Files	5 User-configurable scene files
White Balance	Auto / Manual (Selectable)
Gain	Auto (0 - 20 dB); Manual (-3 - 20 dB), OFF
Output Signal	DVI-D / 3G-SDI
Electronic Shutter	Auto / Manual / OFF 1/60 - 1/10,000

Complies to FCC Part 15 Subpart B, Class A, EN61000-6-4, EN60000-6-2
Toshiba environmental management exceeds RoHS

System Components

For further details, contact your Toshiba ME/FA distributor.

CAMERA HEAD

IK-HD5H

CAMERA CONTROL UNIT

IK-HD5E

CAMERA CABLE

Model	Length
EXC-3HD03	3 m
EXC-3HD06	6 m
EXC-3HD10	10 m
EXC-3HD15	15 m

Connection

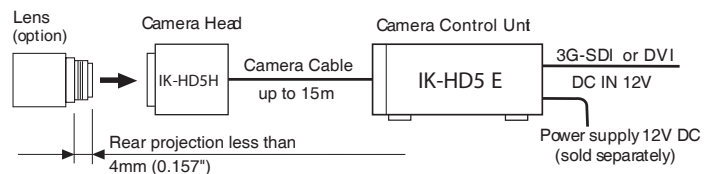

TOSHIBA

Leading Innovation >>>

Toshiba Europe GmbH
www.toshiba.ch/ics
professional@toshiba.ch