



For FA/Machine Vision
3CCD Camera

TF15DA-8

Applicable camera (model)

1 2/3 1/2 1/3 1/4

- FIXED
- TELE
- 3CCD
- MANUAL
- C-mt
- METAL

Fixed Focal

Telephoto Long Focal

For 3CCD Camera

Manual Iris

C Mount

Metal Mount

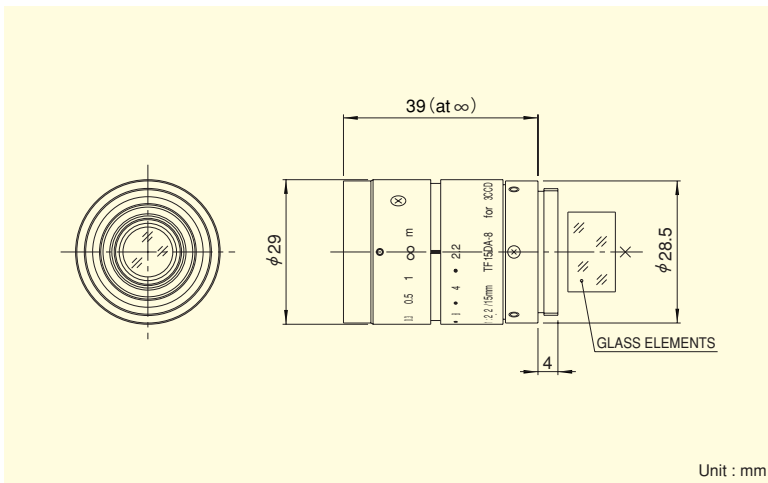

Unit : mm

- Special design for optimizing the image quality of 3CCD cameras.
- Low-distortion design achieving accurate image input.
- Compact, lightweight and robust design, supporting various systems.
- Faithful color reproduction for 3CCD cameras, best suited for advanced monitoring applications.

| | | |
|---|-------------------|--------------------|
| Focal Length (mm) | | 15 |
| Iris Range | | F2.2 ~ F16 · Close |
| Operation | Focus | Manual |
| | Iris | Manual |
| Angle Of View (H×V) | 1/3" | 18°11' × 13°41' |
| Focusing Range (From Front Of The Lens) (m) | | ∞ ~ 0.1 |
| Object Dimensions at M.O.D. (H×V) (mm) | 1/3" | 36 × 27 |
| Back Focal Distance (in air) (mm) | | 16.32 |
| Exit Pupil Position (From Image Plane) (mm) | | -89 |
| Filter Thread (mm) | | M25.5 × 0.5 |
| Mount | | C |
| Mass (g) | | 60 |
| Remarks | •With Metal Mount | |