

XCL Series

High Resolution Cameras

IMAGE SENSING SOLUTIONS

The XCL High Resolution Series from Sony is the perfect fit for a variety of industrial inspection applications such as microscopy, semiconductors, electronic parts, and display panels.



XCL-5005

XCL-5005CR

XCL-U1000

XCL-U1000C

XCL-U100

XCL-5005
XCL-5005CR
XCL-U1000
XCL-U1000C
XCL-U100



Sony **Camera Link** cameras are ideally suited for demanding applications in image processing and Machine Vision (Compact size, PoCL*, High Resolution).

All the cameras in this series conform to the Camera Link standard. Joining the popular XCL High Resolution Series is the extremely compact XCL-U100.

This new camera boasts high-resolution images of UXGA resolution, similar to the existing XCL-U1000/U1000C cameras.

However, the XCL-U100 and the XCL-5005/5005CR cameras are PoCL*-capable, providing users with single-cable operation. The XCL Series delivers outstanding functionality and excellent picture quality, bringing a new level of power and effectiveness to industrial applications.

* PoCL (Power over Camera Link)

Table 1: High-Resolution Image Capture

	XCL-5005	XCL-5005 CR	XCL-U1000	XCL-U1000C	XCL-U100
Image Device	2/3 type Progressive Scan IT CCD		1/1.8 type Progressive Scan IT CCD		
Cell Size	3.45 x 3.45 µm		4.4 x 4.4 µm		
Standard Picture Size (H x V)	2,448 x 2,050		1,600 x 1,200		
Frame Rate	15 fps				
Resolution Depth	8-, 10-, 12-bit B/W	8-, 10-, 12-bit Raw Colour 24-bit RGB Colour	10-bit B/W	24-bit RGB Colour	8-, 10-, 12-bit B/W

Table 2: Supports Camera Link Standard

	XCL-5005	XCL-5005 CR	XCL-U1000	XCL-U1000C	XCL-U100
Interface	PoCL/ Standard Camera Link (Switchable)		Standard Camera Link		PoCL/ Standard Camera Link (Switchable)
Configuration	Base				
Output Data Clock	80 MHz (1 tap), 40 MHz (2 tap)	80 MHz (1 tap), 40 MHz (2 tap, Raw Colour Only)	36 MHz (1 tap)		

Table 3: Hardware Processing

XCL-5005	XCL-5005 CR	XCL-U1000	XCL-U1000C	XCL-U100
Digital Pedestal Digital Gain Detail 3x3 Filter Gamma Correction Binarisation Built-in Test Pattern Mirror Image	Digital Pedestal Pixel Gain RGB Conversion White Balance Gamma Correction Built-in Test Pattern	Detail Gamma Correction Binarisation Built-in Test Pattern	White Balance Matrix Detail Gamma Correction Binarisation Built-in Test Pattern	3x3 Filter Gamma Correction Binarisation Built-in Test Pattern

Features

- High Resolution Image Capture
- Supports Camera Link Standard
- Partial Scan Function
- Hardware Processing
- Compact and Lightweight
- Monitor Output

High Resolution Image Capture

The XCL-5005/5005CR incorporates Sony's ultra-high 5 megapixel resolution CCD, offering incredibly detailed images at 15 frames per second. The XCL-U100 and XCL-U1000/U1000C cameras are equipped with a 1/1.8 type progressive scan IT CCD that provides UXGA resolution, which is ideally suited for a variety of industrial applications requiring high-quality images

Please refer to table 1.

Supports Camera Link Standard

All cameras in the XCL High Resolution Series are equipped with the industry-standard digital Camera Link interfaces. This allows users to quickly capture high-resolution images thanks to simple connectivity with machine vision systems. The XCL-U100 and XCL-5005/5005CR are PoCL-capable, providing users with added flexibility when integrating inspection environments.

Please refer to table 2.

Partial Scan Function

If you select only a specific area of an image to be scanned, the reduced data size and increased frame rate will minimize image processing time. The XCL-U1000/U1000C features vertical partial scanning, while the XCL-U100 and XCL-5005/5005CR support both horizontal partial scanning and vertical partial scanning to accelerate users' inspection tasks.

Hardware Processing

The XCL High Resolution Series cameras have a number of beneficial real-time hardware pre-processing functions such as a 3x3 filter, DTL filter, gamma-correction, and a binarisation mechanism that can be used to emphasise the edges of an object or to change the contrast of an image. These functions provide frame grabbers with images that are easy to process, thus minimising the load on the PC.

Please refer to table 3.

Other Features

- C mount lens
- External trigger
- Binning function (B/W mode only)
- Built-in test pattern



Specifications

	XCL-5005	XCL-5005CR	XCL-U1000	XCL-U1000C	XCL-U100
Image device	2/3 type progressive scan IT CCD		1/1.8 type Progressive scan IT CCD		
Standard picture size (H x V)	2,448 x 2,050 pixels (5,018,400 pixels) *		1,600 x 1,200 pixels (1,920,000 pixels)		
Cell size (H x V)	3.45 x 3.45 μm				
Resolution depth	8/10/12 bits/pixel	Raw Colour: 8/10/12 bits/pixel RGB Colour: 24 bits	10 bits/pixel	RGB Colour: 24 bits	8/10/12 bits/pixel
Lens mount	C mount				
Digital interface	PoCL (Power over Camera Link) / Standard Camera Link, Base Configuration		Standard Camera Link, Base Configuration		PoCL (Power over Camera Link) / Standard Camera Link, Base Configuration
Frame rate	15 fps				
Output data clock	80 MHz (1Tap) / 40 MHz (2 Tap)	80 MHz (1Tap) / 40 MHz (2 Tap, only Raw Colour)	36 MHz (1 Tap)		
Sensitivity	400 lx at F5.6 (0 dB)	2000 lx at F5.6 (0 dB)	400 lx at F5.6 (0 dB)	2000 lx at F8 (0 dB)	400 lx at F5.6 (0 dB)
Minimum illumination	1 lx (GAIN +18 dB, F1.4)	8 lx (GAIN +18 dB, F1.4)	2 lx or less	4 lx or less	1 lx (GAIN +18 dB, F1.4)
Gain control	0 to +18 dB				
White balance	-	Pre-set, Manual, One Push AWB	-	Pre-set, Manual, One Push AWB	-
Readout mode	Normal / Binning / Partial scan	Normal / Partial scan	Normal / Binning / Partial scan	Normal / Partial scan	Normal / Binning / Partial scan
Binning	Vertical (1 x 2)	-	Vertical (1 x 2)	-	Vertical (1 x 2)
Partial scan	Vertical/Horizontal	Vertical/Horizontal	Vertical		Vertical/Horizontal
Shutter speed	2 to 1/10,000 s			1/15 to 1/10,000 s	
Shutter mode	External trigger shutter (Trigger start / Trigger start and exposure duration)				
Extended signal output	DVAL / EXPOSURE / GND output (selectable)		EXPOSURE		DVAL / EXPOSURE / GND output (selectable)
Power requirements	DC 12 V				
Power consumption	3.8 W		5.5 W		2.2 W
Dimensions (W x H x D)	44 x 44 x 57.5 mm (not including protruding parts)		56 x 44 x 95 mm (not including protruding parts)		29 x 29 x 30 mm (not including protruding parts)
Mass	130 g (4.6 oz)		250 g (9 oz)		55 g (2 oz)
Operating temperature	-5 to 45 °C (23 to 113 °F)				
Storage temperature	30 to 60 °C (-22 to 140 °F)				
Operating humidity	20 to 80 % (no condensation)				
Storage humidity	20 to 95 % (no condensation)				
Vibration resistance	10 G (20 to 200 Hz)				
Shock resistance	70 G				
Supplied accessories	Lens mount cap, Operating instructions				

* When RAW data is output, depending on the frame grabber, picture size may be reduced to 2,446 (H) x 2,048 (V).

Pin Assignment & Connectors

1. 12-pin connector

Pin No.	XCL-5005/XCL-5005CR, XCL-U1000/XCL-U1000C, XCL-U100
1	DC IN (GND)
2	DC IN
3	GND
4	NC
5	GND
6	NC
7	NC
8	GND
9	NC
10	EXPOSURE
11	TRIGGER IN
12	GND

2. 6-pin connector

Pin No.	XCL-5005, XCL-5005CR
1	TDX
2	RDX
3	GND
4	NC
5	NC
6	NC

3. 26-pin connector

Pin No.	XCL-5005, XCL-5005CR	XCL-U1000, XCL-U1000C	XCL-U100
1	POWER/INNER_ SHIELD (GND)	INNER_SHIELD (GND)	POWER/INNER_ SHIELD (GND)
2		X0- output (signal)	
3		X1- output (signal)	
4		X2- output (signal)	
5		XCLK- output (signal)	
6		X3- output (signal)	
7		SerTC+ (signal)	
8		SerTFG- (signal)	
9		TRIG- input (signal)	
10		NC	
11		NC	
12		NC	
13		INNER_SHIELD (GND)	

Pin No.	XCL-5005, XCL-5005CR	XCL-U1000, XCL-U1000C	XCL-U100
14		INNER_SHIELD (GND)	
15		X0+ output (signal)	
16		X1+ output (signal)	
17		X2+ output (signal)	
18		XCLK+ output (signal)	
19		X3+ output (signal)	
20		SerTC- (signal)	
21		SerTFG+ (signal)	
22		TRIG+ input (signal)	
23		NC	
24		NC	
25		NC	
26	POWER/INNER_ SHIELD (GND)	INNER_SHIELD (GND)	POWER/INNER_ SHIELD (GND)

Dimensions (mm)

XCL-5005/XCL-5005CR

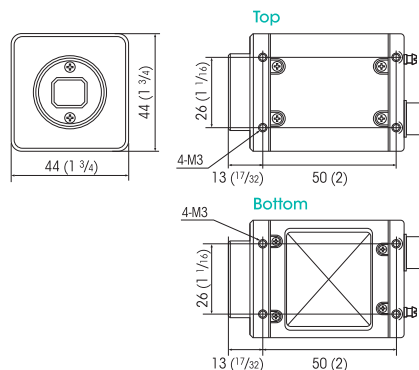

XCL-U1000/XCL-U1000C

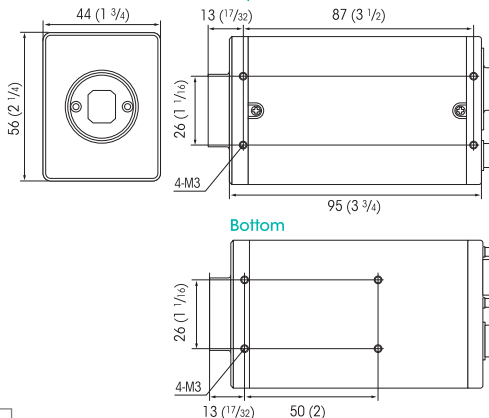

XCL-U100

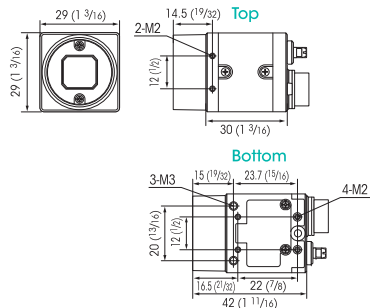

Distributed by

© 2009 Sony Electronics Inc. All rights reserved. Reproduction in whole or in part without written permission is prohibited. Design, features and specifications are subject to change without notice. All non-metric weights and measurements are approximate. Sony is a registered trademark of Sony Corporation. All other trademarks are the properties of their respective owners.